

Technical guide



Design and operating information for hot water boilers
up to 110 °C to EN 14394 and EN 12828,
up to 120 °C to EN 12953 and EN 14394

VITOMAX 100-LW Type M148

VITOMAX 200-LW Type M62A, M64A

VITOMAX 300-LW Type M82A, M84A

VITOMAX 200-WS Type M250

VITOMAX 300-LT Type M343

Index

1. Vitomax 100-LW, type M148, 0.65 to 6.0 MW	1. 1 Product description	6
	1. 2 Operating conditions	6
	1. 3 Tested quality	6
2. Vitomax 100-LW, type M148 system pack, 2.3 to 6.0 MW	2. 1 Product description	7
	2. 2 Standard delivery	7
	2. 3 Accessories	7
	2. 4 Example: Vitomax 100-LW, type M148 system pack with accessories	8
	2. 5 Operating conditions	8
3. Vitomax 200-LW, type M62A and M64A, 2.3 to 20.0 MW	3. 1 Product description	9
	3. 2 Operating conditions	9
	3. 3 Tested quality	9
4. Vitomax 200-LW, type M62A system pack, 2.3 to 6.0 MW	4. 1 Product description	10
	4. 2 Standard delivery	10
	4. 3 Accessories	10
	4. 4 Example: Vitomax 200-LW, type M62A system pack with accessories	11
	4. 5 Operating conditions	11
5. Vitomax 300-LW, type M82A and M84A, 2.1 to 20.0 MW (low NOx series)	5. 1 Product description	12
	5. 2 Operating conditions	12
	5. 3 Tested quality	12
6. Vitomax 200-WS, type M250, 1.75 to 11.63 MW	6. 1 Product description	13
	6. 2 Operating conditions	13
	6. 3 Tested quality	13
7. Vitomax 300-LT, type M343, 1.86 to 5.9 MW	7. 1 Product description	14
	7. 2 Operating conditions	14
	7. 3 Tested quality	14
8. Flue gas/water heat exchanger Vitotrans 100-LW, Vitotrans 200-LW	8. 1 Product description	15
	■ Product description	15
	■ Dimensions	17
	■ Shipping dimensions and weights	18
	■ Delivered condition	18
	■ On-site tasks	18
	■ Tested quality	18
9. Vitotrans 300	9. 1 Product description	19
	■ Benefits	19
	■ Delivered condition	19
	■ Tested quality	20
	9. 2 Specification	20
	■ Specification	20
	■ Pressure drop on the heating water side	23
	■ Output data for gas operation	23
10. Design information	10. 1 Transport, delivery, handling and siting	24
	■ Transportation of Vitomax boilers	24
	■ Delivery	25
	■ Handling and siting	25
	■ Boiler room	25
	■ Load-bearing boiler cover	26
	■ Modular boiler control platform	26
	10. 2 System design	26
	■ Flow temperatures	26
	■ Safety temperatures	26
	■ Selection of rated heating output	26
	■ Requirements through heat load	27
	■ Pressure maintaining systems	27
	■ Pump controlled pressure maintaining systems	27
	10. 3 Water connection	27
	■ Heating connections	27
	■ Boiler circuit and shunt pumps	27
	■ System examples	28

10. 4	Safety equipment for hot water boilers	28
	■ General information	29
	■ Safety accessories selection table	29
10. 5	Fuels	29
10. 6	Burners	30
	■ Suitable burners	30
	■ Burner adjustment	30
10. 7	Flue gas routing	30
	■ Requirements in accordance with the Sample Combustion Order [Germany]	30
	■ Sizing the flue system to EN 13384	31
10. 8	Sound insulation	31
	■ Attenuating airborne noise	31
	■ Insulation against structure-borne noise	32
	■ Sound insulation accessories	32
10. 9	Standard values for water quality	32
	■ Heating systems with rated operating temperatures up to 100 °C (VDI 2035)	32
	■ Heating systems with permissible flow temperatures in excess of 100 °C (VdTÜV DS 1466)	32
	■ Using antifreeze in boilers	33
	■ Prevention of damage through corrosion on the water side	34
10.10	Flue gas/water heat exchangers	34
	■ Installing a flue gas/water heat exchanger downstream for higher efficiency	34
	■ Energy savings through the use of flue gas/water heat exchangers	34
	■ Calculation of possible energy savings (B _E)	35
	■ Hydraulic connection	35
	■ Condensate and neutralisation (Vitotrans 300)	36
	■ Positioning the neutralising system	36
11.	Control units	
11. 1	Overview of boiler control units and control panels	36
	■ Single boiler systems	36
	■ Multi boiler systems	37
	■ Switching points	38
11. 2	Components in the delivered condition	38
	■ Allocation to control unit types	38
	■ Boiler water temperature sensor	38
	■ Cylinder temperature sensor	39
	■ Outside temperature sensor	39
11. 3	Vitotronic 100, type GC1B, part no. 7498 901	39
	■ Specification	39
	■ Delivered condition	41
11. 4	Vitotronic 200, type GW1B, part no. 7498 902	41
	■ Specification	41
	■ Delivered condition	43
11. 5	Vitotronic 300-K, type MW1B, part no. 7498 906	43
	■ Specification	43
	■ Delivered condition	45

11. 6	Control unit accessories	46
	■ Allocation of accessories according to oil/gas boiler control unit type	46
	■ Information regarding Vitotrol 200A and 300A	46
	■ Vitotrol 200A	46
	■ Vitotrol 300A	47
	■ Information regarding the Vitotrol 200 RF and Vitotrol 300 RF	48
	■ Vitotrol 200 RF	48
	■ Vitotrol 300 RF with table-top dock	48
	■ Vitotrol 300 RF with wall mounting bracket	49
	■ Wireless base station	50
	■ Wireless outside temperature sensor	50
	■ Wireless repeater	51
	■ Room temperature sensor	51
	■ Contact temperature sensor	51
	■ Immersion temperature sensor	52
	■ Sensor well	52
	■ Sensor well	52
	■ Sensor well	52
	■ Flue gas temperature sensor	52
	■ Cylinder temperature sensor	53
	■ Mixer extension kit	53
	■ Mixer motor for flanged mixers	53
	■ Plug 20	53
	■ Plug 52	53
	■ Plugs for sensors	53
	■ Immersion thermostat	54
	■ Contact thermostat	54
	■ Radio clock receiver	54
	■ Plug-in adaptor for external safety equipment	54
	■ Contactor relay	55
	■ Mating plugs 41 and 90	55
	■ Mounting kit for control panel fitting	55
	■ Solar control module, type SM1	56
	■ Extension AM1	57
	■ Extension EA1	57
	■ Vitocom 100, type LAN1	58
	■ Vitocom 100, type GSM	58
	■ Vitocom 200, type GP1	59
	■ Vitocom 300, type FA5, FI2, GP2	59
	■ LON connecting cable for data exchange between control units	61
	■ Extension of the connecting cable	61
	■ Terminator (2 pce)	61
	■ LON communication module	62
11. 7	Vitogate 200, type EIB	62
	■ Part no. Z009 466	62
11. 8	On-site connections	62
	■ Additional functions for single boiler systems with a Vitotronic 200, type GW1B	62
	■ Additional functions for multi boiler systems with Vitotronic 300-K, type MW1B or Vitotronic 100, type GC1B via LON	64
	■ Connection of on-site control units to extension EA1 in single boiler systems	64
	■ Connection of on-site control units to the Vitotronic 100, type GC1B, in single boiler systems	65
	■ Connection of on-site control units to extension EA1 in multi boiler systems	66
	■ Boiler sequence control with on-site cascade control unit — connections to the Vitotronic 100, type GC1B	68
	■ Hook-up of on-site control units via LON	69

Index (cont.)

12. Appendix		
	12. 1 Safety regulations and requirements	69
	■ Duty of notification and required permits	69
	■ Permit requirement and testing to the Health & Safety at Work Act (BetrSichV) [Germany]	69
	■ General information regarding low pressure hot water boilers with safety temperatures of up to 110 °C/120 °C	70
	■ Sizing the flame tube	70
	■ Flame tube temperature monitor	71
	■ Gas installation	71
	■ Pipe connections	71
	■ Electrical installation	71
	■ Operating instructions	71
	■ Flue system	71
	■ German Immissions Order (BImSchV)	71
	■ Checks as part of the Building Regulations approval process	71
13. Keyword index	72

1.1 Product description

- Oil/gas boiler
- Hot water boiler according to TRD 702 for permissible flow temperature (= safety temperature) up to 110 °C
- Permissible operating pressure: 6 and 10 bar
- Boiler efficiency corresponds to 91.5 %.
- Three-pass reversing flame boiler with low heating surface load – clean combustion with low nitrogen oxide emissions.
- The rear reversing chamber is water-cooled.
- No minimum heating water flow rate required – wide water galleries and a large water content provide excellent natural circulation and reliable heat transfer – simplified hydraulic connection.
- Low pressure drop on the hot gas side, through convection heating surfaces with large hot gas pipes.
- Low radiation losses through 100 mm thick composite thermal insulation.
- Operation and service are simple and affordable, since the boiler and the large cleaning door do not require firebrick lining.
- Load-bearing cover on top of the boiler as part of the standard delivery – simplifies installation and maintenance and protects the thermal insulation against damage.
- As an option, a modular control platform is available (from 2 m boiler top edge).
- Intermediate flow piece for the connection of system-specific equipment, available as an option.

1.2 Operating conditions

	M148 requirements	
	with Vitotrans 100/200-LW flue gas/ water heat exchanger*1	without flue gas/water heat exchanger
1. Heating water flow rate	None	None
2. Boiler return temperature (minimum value)	– Oil operation 65 °C – Gas operation 70 °C	– Oil operation 50 °C – Gas operation 55 °C
3. Maximum spread	– Oil operation 30 K – Gas operation 25 K	40 K
4. Two-stage burner operation	None	None
5. Modulating operation	None	None
6. Reduced mode and weekend setback	Lag boilers in multi boiler systems can be shut down	

Note

For water quality requirements, see page 32.

1.3 Tested quality

 CE designation according to current EC Directives.

*1 When operating with a condensing heat exchanger, the operating conditions are in line with those for boilers without heat exchanger.

2.1 Product description

- Oil/gas boiler
- Hot water boiler according to TRD 702 for permissible flow temperature (= safety temperature) up to 110 °C
- Permissible operating pressure 6 and 10 bar
- Boiler efficiency corresponds to 91.5 %, maximum system efficiency of 95.5 % with the Vitotrans 200-LW
- Three-pass reversing flame boiler with low heating surface load – clean combustion with low nitrogen oxide emissions.
- The rear reversing chamber is water-cooled.
- No minimum heating water flow rate required – wide water galleries and a large water content provide excellent natural circulation and reliable heat transfer – simplified hydraulic connection.
- Low pressure drop on the hot gas side, through convection heating surfaces with large hot gas pipes.
- Low radiation losses through 100 mm thick composite thermal insulation.
- Operation and service are simple and affordable, since the boiler and the large cleaning door do not require firebrick lining.
- Load-bearing cover on top of the boiler as part of the standard delivery – simplifies installation and maintenance and protects the thermal insulation against damage.
- Walk-on, modular control platform available as an option (from 2 m height).

2.2 Standard delivery

- Oil/gas boiler type M148 with drilled burner plate, from boiler size 8 (3.5 MW) prepared for a control platform
- Burner
- Maximum pressure limiter
- Minimum pressure limiter
- Straight-through shut-off valve for minimum and maximum pressure limiters
- Safety valve
- Flash trap replacement set
- Intermediate flow piece with low water indicator
- Vitocontrol control panel with fitted Vitotronic 100 (type GC1B)
- Control panel with adaptor
- Flue gas temperature sensor for installation in the flue outlet
- Dial thermometer with sensor well
- Fitting assembly with pressure gauge
- Shut-off damper for boiler flow and return connectors
- Mating flanges to boiler flow, boiler return and drain connectors
- Drain shut-off valve

2.3 Accessories

- Return temperature raising facility (RTRF) with shunt pump (for specification see RTRF datasheet)
- Return temperature raising facility with 3-way mixing valve and boiler circuit pump (for specification, see RTRF datasheet)
- Vitotrans 100/200-LW flue gas/water heat exchanger, with full flow and mating flanges on the water side for improved efficiency (for specification see the Vitotrans 100/200-LW datasheet)
- Flue gas silencer, flanged with mating flanges (for specification see the manufacturer's datasheet)
- Motorised flue gas damper, flanged with mating flanges (for specification see the manufacturer's datasheet)
- Gas train with 100 mbar or 300 mbar supply pressure
- Modular control platform from boiler size 8/3.5 MW (for specification see the boiler control platform datasheet)

2.4 Example: Vitomax 100-LW, type M148 system pack with accessories

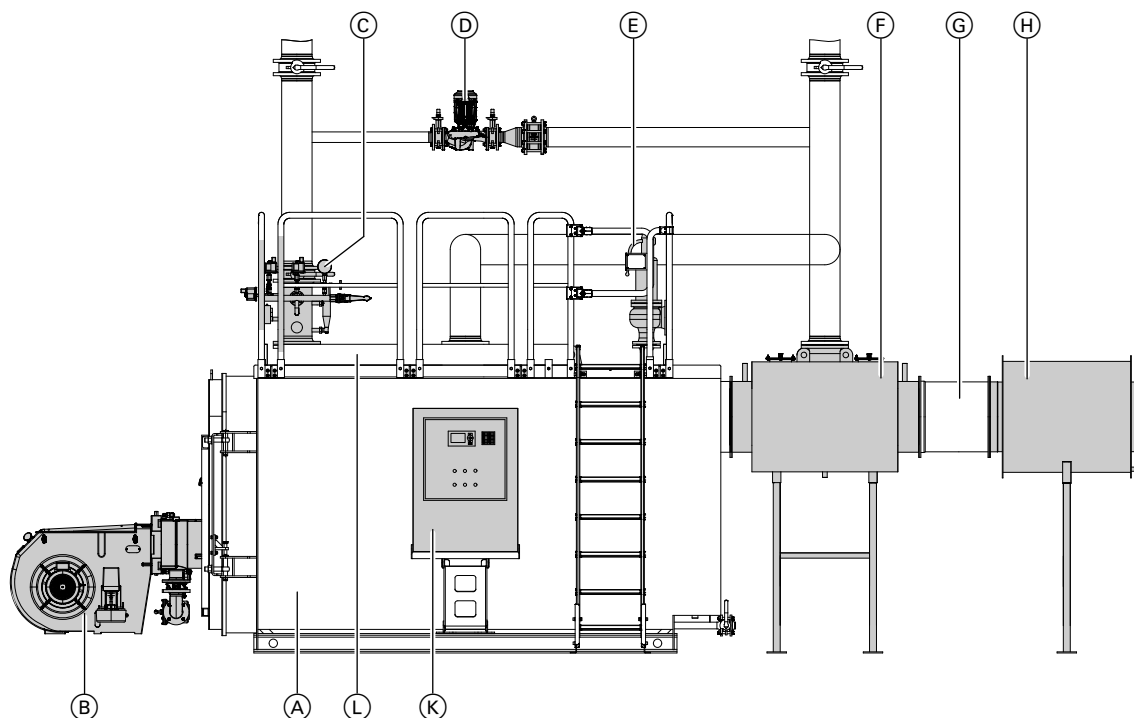

- | | |
|--|--|
| <ul style="list-style-type: none"> (A) Low pressure hot water boiler (B) Combustion system (C) Intermediate flow piece with safety control and limiting equipment (D) Return temperature raising facility (option) (E) Safety valve | <ul style="list-style-type: none"> (F) Vitotrans 100/200-LS flue gas/water heat exchanger (option) (G) Flue gas damper (option) (H) Flue gas silencer (option) (K) Control panel (Vitocontrol with Vitotronic) (L) Modular boiler control platform (option) |
|--|--|

Note

System examples with return temperature raising facility, see technical guide "System examples"

2.5 Operating conditions

	M148 system pack requirements	
	with Vitotrans 100/200-LW flue gas/ water heat exchanger*2	without flue gas/water heat exchanger
1. Heating water flow rate	None	None
2. Boiler return temperature (minimum value)	– Oil operation 65 °C – Gas operation 70 °C	– Oil operation 50 °C – Gas operation 55 °C
3. Maximum spread	– Oil operation 30 K – Gas operation 25 K	40 K
4. Two-stage burner operation	None	None
5. Modulating operation	None	None
6. Reduced mode and weekend setback	Lag boilers in multi boiler systems can be shut down	

Note

For water quality requirements, see page 32.

*2 When operating with a condensing heat exchanger, the operating conditions are in line with those for boilers without heat exchanger.

3.1 Product description

- Oil/gas boiler for operation at a constant boiler water temperature
- Hot water boiler to TRD 702 for permissible flow temperatures (= safety temperature) up to 110 or 120 °C
- Permissible operating pressure 6, 10 and 16 bar
- Boiler efficiency corresponds to 92 %.
- CE designation:
 - for permissible flow temperatures (= safety temperatures) up to 110 °C to Gas Appliances Directive 2009/142/EC or
 - for permissible flow temperatures (= safety temperatures) up to 120 °C to Pressure Equipment Directive 97/23/EC
- Three-pass boiler with low combustion chamber loading - clean combustion with low nitrogen oxide emissions.
- The rear reversing chamber is water-cooled.
- No minimum heating water flow rate required – wide water galleries and a large water content provide excellent natural circulation and reliable heat transfer – simplified hydraulic connection.
- Low pressure drop on the hot gas side, through convection heating surfaces with large hot gas pipes.
- Low energy consumption through low flue gas temperatures and 100 mm thick composite thermal insulation.
- Operation and service are easy and affordable, since the boiler and the large cleaning doors do not require firebrick lining.
- Load-bearing cover on top of the boiler as part of the standard delivery – simplifies installation and maintenance and protects the thermal insulation against damage.
- Optional modular control platform from boiler size 8 (3.5 MW) (for specification see the boiler control platform datasheet)
- Optional intermediate flow piece for safety temperatures of 110 °C or 120 °C.
- 4 % higher efficiency through the Vitotrans 200-LW or up to 11 % by utilising condensing technology with the stainless steel Vitotrans 300 flue gas/water heat exchanger.
- The Vitocontrol control panel enables the regulation of all boiler-specific control equipment.
- As an option, the Vitomax 200-LW can either be equipped with individual thermostats or the Vitotronic boiler control unit.
- Optionally increased combustion output/boiler output with flame tube temperature monitor to DIN EN 12953.
In Germany, operation of the boilers in accordance with BetrSichV must be ensured.

3.2 Operating conditions

	M62A, M64A requirements	
	with Vitotrans 100/200-LW flue gas/water heat exchanger* ³	without flue gas/water heat exchanger
1. Heating water flow rate	None	None
2. Boiler return temperature (minimum value)	– Oil operation 65 °C – Gas operation 70 °C	– Oil operation 50 °C – Gas operation 55 °C
3. Maximum spread	– Oil operation 30 K – Gas operation 25 K	40 K
4. Two-stage burner operation	None	None
5. Modulating operation	None	None
6. Reduced mode and weekend setback	Lag boilers in multi boiler systems can be shut down	

Note

For water quality requirements, see page 32.

3.3 Tested quality

 CE designation according to current EC Directives.

*³ When operating with a condensing heat exchanger, the operating conditions are in line with those for boilers without heat exchanger.

4.1 Product description

- Oil/gas boiler
- Hot water boiler according to TRD 702 for permissible flow temperature (= safety temperature) up to 110 °C
- Permissible operating pressure: 6 and 10 bar
- Boiler efficiency corresponds to 92 %, maximum system efficiency of 96 % with the Vitotrans 200-LW
- Three-pass reversing flame boiler with low heating surface load – clean combustion with low nitrogen oxide emissions.
- The rear reversing chamber is water-cooled.
- No minimum heating water flow rate required – wide water galleries and a large water content provide excellent natural circulation and reliable heat transfer – simplified hydraulic connection.
- Low pressure drop on the hot gas side, through convection heating surfaces with large hot gas pipes.
- Low radiation losses through 100 mm thick composite thermal insulation.
- Operation and service are easy and affordable, since the boiler and the large cleaning doors do not require firebrick lining.
- Load-bearing cover on top of the boiler as part of the standard delivery – simplifies installation and maintenance and protects the thermal insulation against damage.
- As an option, a walk-on control platform is available (from 2 m height).
- Intermediate flow piece for the connection of system-specific equipment, available as an option.

4.2 Standard delivery

- Oil/gas boiler type M62A with drilled burner plate, from boiler size 8 (3.5 MW) prepared for a control platform
- Burner
- Maximum pressure limiter
- Minimum pressure limiter
- Straight-through shut-off valve for minimum and maximum pressure limiters
- Safety valve
- Flash trap replacement set
- Intermediate flow piece with low water indicator
- Vitocontrol control panel with fitted Vitotronic 100 (type GC1B)
- Control panel with adaptor only in conjunction with I-beam boiler support
- Temperature sensor for flue outlet
- Dial thermometer with sensor well
- Fitting assembly with pressure gauge
- Shut-off damper for boiler flow and return connectors
- Mating flanges to boiler flow, boiler return and drain connectors
- Drain shut-off valve

4.3 Accessories

- Return temperature raising facility (RTRF) with shunt pump (for specification, see RTRF datasheet)
- Return temperature raising facility with 3-way mixing valve and boiler circuit pump (for specification, see RTRF datasheet)
- Vitotrans 100/200-LW flue gas/water heat exchanger, with full flow and mating flanges on the water side for improved efficiency (for specification see the Vitotrans 100/200-LW datasheet)
- Flue gas silencer, flanged with mating flanges (for specification see the manufacturer's datasheet)
- Motorised flue gas damper, flanged with mating flanges (for specification see the manufacturer's datasheet)
- Gas train with 100 mbar or 300 mbar supply pressure
- Modular control platform from boiler size 8 (3.5 MW) (for specification see the boiler control platform datasheet)

4.4 Example: Vitomax 200-LW, type M62A system pack with accessories

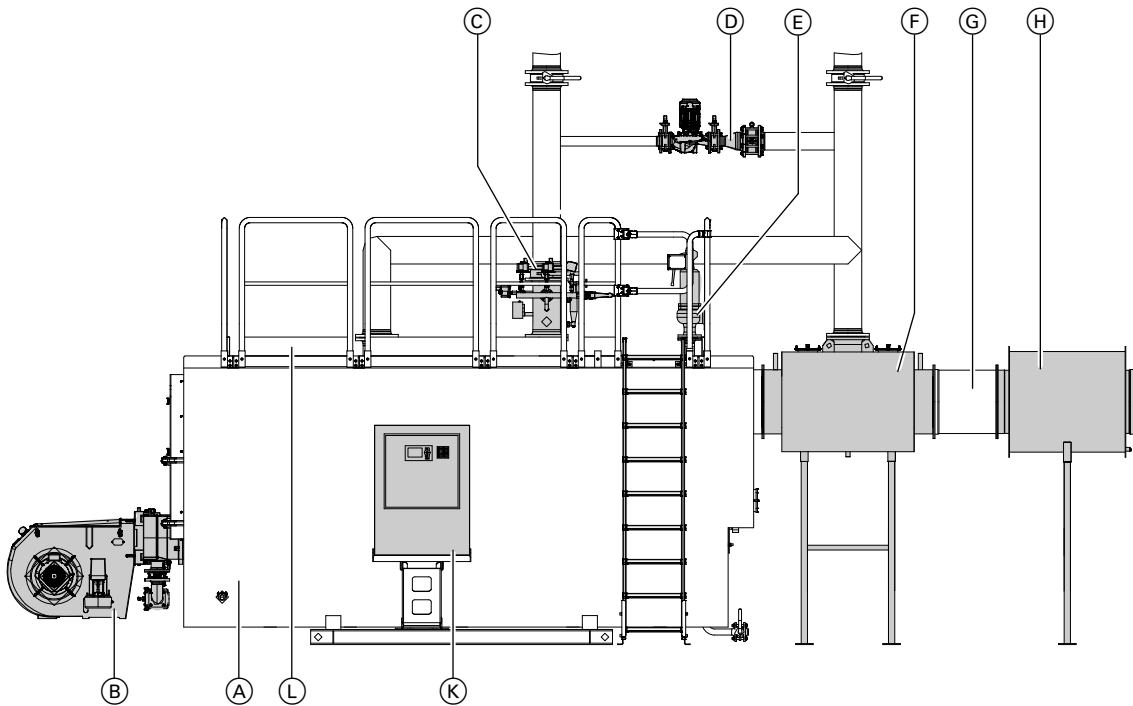

- (A) Low pressure hot water boiler
- (B) Combustion system
- (C) Intermediate flow piece with safety control and limiting equipment
- (D) Return temperature raising facility (option)
- (E) Safety valve
- (F) Vitotrans 100/200-LW flue gas/water heat exchanger (option)
- (G) Flue gas damper (option)
- (H) Flue gas silencer (option)
- (K) Control panel (Vitocontrol with Vitotronic)
- (L) Modular boiler control platform (option)

Note

System examples with return temperature raising facility, see technical guide "System examples"

4.5 Operating conditions

	Requirements
1. Heating water flow rate	None
2. Boiler return temperature (minimum value)	– Oil operation 50 °C – Gas operation 55 °C
3. Lower boiler water temperature	70 °C
4. Two-stage burner operation	None
5. Modulating operation	None
6. Reduced mode	Not possible
7. Weekend setback	Not possible

Note

For water quality requirements, see page 32.

Vitomax 300-LW, type M82A and M84A, 2.1 to 20.0 MW (low NOx series)

5.1 Product description

- Oil/gas boiler for operation at a constant boiler water temperature in reduced emissions version
 - Hot water boiler to TRD 702 for permissible flow temperatures (= safety temperature) up to 110 or 120 °C
 - Permissible operating pressure 6, 10 and 16 bar
 - Boiler efficiency corresponds to 92 % (gas) / 92.5 % (oil).
 - CE designation:
 - for permissible flow temperatures (= safety temperatures) up to 110 °C to Gas Appliances Directive 2009/142/EC
 - or
 - for permissible flow temperatures (= safety temperatures) up to 120 °C to Pressure Equipment Directive 97/23/EC
 - Three-pass boiler with low combustion chamber loading - clean combustion with low nitrogen oxide emissions.
 - The rear reversing chamber is water-cooled.
 - No minimum heating water flow rate required – wide water galleries and a large water content provide excellent natural circulation and reliable heat transfer – simplified hydraulic connection.
 - Low pressure drop on the hot gas side, through convection heating surfaces with large hot gas pipes.
 - Low energy consumption through low flue gas temperatures and 100 mm thick composite thermal insulation.
 - Operation and service are easy and affordable, since the boiler and the large cleaning doors do not require firebrick lining.
 - Load-bearing cover on top of the boiler as part of the standard delivery – simplifies installation and maintenance and protects the thermal insulation against damage.
 - Modular control platform from boiler size 8 (3.5 MW) on request
 - Optional intermediate flow piece for safety temperatures of 110 °C or 120 °C.
 - The Vitocontrol control panel enables the regulation of all boiler-specific control equipment.
 - As an option, the Vitomax 300-LW can either be equipped with individual thermostats or the Vitotronic boiler control unit.
 - Optionally increased combustion output/boiler output with flame tube temperature monitor to DIN EN 12953.
- In Germany, operation of the boilers in accordance with BetrSichV must be ensured.

5.2 Operating conditions

	M62A, M64A requirements	
	with Vitotrans 100/200-LW flue gas/ water heat exchanger	without flue gas/water heat exchanger
1. Heating water flow rate	None	None
2. Boiler return temperature (minimum value)	– Oil operation 65 °C – Gas operation 70 °C	– Oil operation 50 °C – Gas operation 55 °C
3. Maximum spread	– Oil operation 30 K – Gas operation 25 K	40 K
4. Two-stage burner operation	None	None
5. Modulating operation	None	None
6. Reduced mode and weekend setback	Lag boilers in multi boiler systems can be shut down	

Note

For water quality requirements, see page 32.

5.3 Tested quality

 CE designation according to current EC Directives.

6.1 Product description

- Oil/gas boiler for operation at a constant boiler water temperature
- Hot water boiler for permissible flow temperatures (= safety temperatures) up to 110 °C
- Permissible operating pressure 3 bar
- Boiler efficiency corresponds to 94 %.
- CE designation to Gas Appliances Directive 2009/142/EC
- Three-pass boiler with extremely low combustion chamber loading ($\leq 1.0 \text{ MW/m}^3$) – clean combustion with low nitrogen oxide emissions.
- The rear and front reversing chambers are water-cooled.
- No minimum heating water flow rate required – wide water galleries and a large water content provide excellent natural circulation and reliable heat transfer – simplified hydraulic connection.
- Low pressure drop on the hot gas side, through convection heating surfaces with large hot gas pipes.
- Low radiation losses through 100 mm thick composite insulation and water-cooled front panel.
- Additional DHW circulation pipe in the lower boiler section (shunt pipe) is designed for the internal circulation of the boiler water and therefore for the optimum storage of heat inside the boiler.
- High operational reliability and a long service life are ensured through wide water galleries and large water content with excellent natural circulation and reliable heat transfer.
- Operation and service are simple and affordable, since the boiler and the large cleaning door do not require firebrick lining.
- Load-bearing cover on top of the boiler as part of the standard delivery – simplifies installation and maintenance and protects the thermal insulation against damage.
- Intermediate flow piece as essential equipment for 110 °C safety temperature, available as an option.
- Modular control platform from 2 m boiler top edge (for specification see the boiler control platform datasheet)
- The Vitocontrol control panel enables the switching of all boiler-specific control equipment.

6.2 Operating conditions

	M250 requirements without flue gas/water heat exchanger
1. Heating water flow rate	None
2. Boiler return temperature (minimum value)	– Oil operation 65 °C – Gas operation 65 °C
3. Maximum spread	– Oil operation 40 K – Gas operation 40 K
4. Two-stage burner operation	None
5. Modulating operation	None
6. Reduced mode and weekend setback	Lag boilers in multi boiler systems can be shut down

Note

For water quality requirements, see page 32.

6.3 Tested quality

 CE designation according to current EC Directives.

7.1 Product description

- Low temperature oil/gas boiler with multi layered convection heating surfaces for operation with modulating boiler water temperatures
- Permissible flow temperature (= safety temperature) up to 110 °C or 120 °C
- Permissible operating pressure 6 bar
- Boiler efficiency corresponds to 93.5 %.
- Standard seasonal efficiency to EN 4702–8 at 75/60 °C flow and return temperature corresponds to 96 % (H_i [net cv]).
- CE designation:
 - for permissible flow temperatures (= safety temperatures) up to 110 °C to Gas Appliances Directive 2009/142/EC
 - or
 - for permissible flow temperatures (= safety temperatures) up to 120 °C to Pressure Equipment Directive 97/23/EC
- Three-pass boiler with low combustion chamber loading (≤ 1.2 MW/m³) – clean combustion with low nitrogen oxide emissions.
- Low radiation losses through 120 mm thick composite thermal insulation. The flue gas collector is also fitted with thermal insulation.
- The rear and front reversing chambers are water-cooled.
- High operational reliability and a long service life through multi layered convection heating surfaces made from Duplex tubes.
- Low pressure drop on the hot gas side, through convection heating surfaces with large hot gas pipes.
- No minimum heating water flow rate required – wide water galleries and a large water content provide excellent natural circulation and reliable heat transfer – simplified hydraulic connection.
- Low minimum return temperatures of 38 °C for oil operation and 45 °C for gas operation.
- Low energy consumption due to modulating boiler water temperature.
- No additional intermediate flow piece is required with safety temperatures of up to 110 °C; all necessary connections are already fitted to the boiler.
- Low maintenance requirement through water-cooled front and rear reversing chambers without firebrick lining
- Operation and service are easy and affordable, since the boiler and the large cleaning doors do not require firebrick lining.
- Load-bearing cover on top of the boiler as part of the standard delivery – simplifies installation and maintenance and protects the thermal insulation against damage.
- Standard efficiency improved by up to 10 % due to the utilisation of condensing technology, with stainless steel Vitotrans 300 flue gas/water heat exchanger.
- Economical and safe operation of the heating system through the digital Vitotronic control system with communication capability. Standardised LON for complete integration into building management systems.

7.2 Operating conditions

Operation with rated combustion output	Requirements	
	≥ 60 %	< 60 %
1. Heating water flow rate	None	None
2. Boiler return temperature (minimum value)	– Oil operation 38 °C – Gas operation 45 °C	– Oil operation 53 °C – Gas operation 53 °C
3. Two-stage burner operation	Minimum load 60 % of rated combustion output	No minimum load required
4. Modulating burner operation	Minimum load 60 % of rated combustion output	No minimum load required
5. Reduced mode and weekend setback	Lag boilers in multi boiler systems can be shut down	

Note

For water quality requirements, see page 32.

7.3 Tested quality

 CE designation according to current EC Directives.

Flue gas/water heat exchanger Vitotrans 100-LW, Vitotrans 200-LW

8.1 Product description

Product description

- Flue gas/water heat exchanger for gas and fuel oil operation (EL)
- Can be used with Vitomax boilers for the 100-LW and 200-LW series with rated heating output from 2.3 to 6 MW
- Female connections for flue gas temperature sensors
- Thermal insulation
- Height-adjustable frame
- Special versions on request

Specification Vitotrans 100-LW for Vitomax 100-LW type M148

Rated boiler heating output	kW	2300	2900	3500	4200	5000	6000
Rated heating output AWT (gas) ^{*4}	kW	73	90	116	139	164	195
Rated heating output AWT (fuel oil EL) ^{*4}	kW	66	81	104	125	148	175
Permissible operating pressure	bar	16					
Permissible flow temperature	°C	120					
Permissible return temperature	°C	65 ^{*5}					
Pressure drop on the water side	mbar	177	180	180	180	184	185
Pressure drop on the flue gas side (gas) ^{*6}	Pa	66	78	148	162	171	193
Pressure drop on the flue gas side (fuel oil EL) ^{*6}	Pa	59	68	132	145	153	172
Flue gas mass flow rate (gas)	kg/h	1.5225 x combustion output in kW					
Flue gas mass flow rate (fuel oil EL)	kg/h	1.5 x combustion output in kW					
Total length (dimension g)	mm	1408	1408	1408	1408	1408	1408
Total width (dimension e)	mm	1236	1335	1375	1375	1425	1599
Total height (dimension f)	mm	1976	2076	2171	2342	2437	2557
Weight when empty incl. thermal insulation	kg	420	447	494	548	565	718
Water content	m ³	0.11	0.11	0.14	0.16	0.17	0.23
Flue gas volume	m ³	0.27	0.31	0.29	0.35	0.38	0.46
Flow and return connections	DN/PN	150/40	150/40	200/25	200/25	200/25	250/25
Drain on the water side	G	½					
Drain on the gas side	R	½					
Female connections	R	½					
Flue gas connection, external	Ø mm	410	460	510	560	610	660
Flue gas connection, internal	Ø mm	400	450	500	550	600	650

Specification Vitotrans 100-LW for Vitomax 200-LW type M62A

Rated boiler heating output	kW	2300	2800	3500	4500	6000	
Rated heating output AWT (gas) ^{*7}	kW	60	53	95	100	159	
Rated heating output AWT (fuel oil EL) ^{*7}	kW	55	48	87	92	146	
Permissible operating pressure	bar	16					
Permissible flow temperature	°C	120					
Permissible return temperature	°C	65 ^{*5}					
Pressure drop on the water side	mbar	177	185	180	186	185	
Pressure drop on the flue gas side (gas) ^{*6}	Pa	63	69	142	143	185	
Pressure drop on the flue gas side (fuel oil EL) ^{*6}	Pa	57	62	127	128	166	
Flue gas mass flow rate (gas)	kg/h	1.5225 x combustion output in kW					
Flue gas mass flow rate (fuel oil EL)	kg/h	1.5 x combustion output in kW					
Total length (dimension g)	mm	1408	1408	1408	1408	1408	
Total width (dimension f)	mm	1236	1229	1375	1382	1666	
Total height (dimension e)	mm	2191	2271	2396	2537	2697	
Weight when empty incl. thermal insulation	kg	420	490	494	535	690	
Water content	m ³	0.11	0.11	0.14	0.16	0.30	
Flue gas volume	m ³	0.27	0.31	0.29	0.35	0.46	
Flow and return connections	DN/PN	150/40	150/40	200/25	200/25	250/25	
Drain on the water side	G	½					
Drain on the gas side	R	½					
Female connections	R	½					
Flue gas connection, external	Ø mm	410	460	510	560	660	
Flue gas connection, internal	Ø mm	400	450	500	550	650	

^{*4} Heating output of the Vitotrans 100-LW at a flue gas inlet temperature of 205 °C (HEL) or 215 °C (gas) and system temperatures of 90/70 °C.

^{*5} Never let the temperature fall below the dew point temperature of the flue gas.

^{*6} Pressure drop on the hot gas side at rated heating output. The burner must be able to overcome the hot gas pressure drop of the boiler and the Vitotrans 100/200-LW.

^{*7} Heating output of the Vitotrans 100-LW at a flue gas inlet temperature of 184 °C (HEL) or 190 °C (gas) and system temperatures of 90/70 °C.

Flue gas/water heat exchanger Vitotrans 100-LW, Vitotrans 200-LW (cont.)

Specification Vitotrans 200-LW for Vitomax 100-LW type M148

Rated boiler heating output	kW	2300	2900	3500	4200	5000	6000
Rated heating output AWT (gas) ^{*8}	kW	110	140	171	207	240	296
Rated heating output AWT (fuel oil EL) ^{*8}	kW	97	124	151	184	213	262
Permissible operating pressure	bar	16					
Permissible flow temperature	°C	120					
Permissible return temperature	°C	65 ^{*5}					
Pressure drop on the water side	mbar	174	174	174	175	175	176
Pressure drop on the flue gas side (gas) ^{*6}	Pa	123	127	127	196	156	217
Pressure drop on the flue gas side (fuel oil EL) ^{*6}	Pa	110	114	113	175	140	194
Flue gas mass flow rate (gas)	kg/h	1.5225 x combustion output in kW					
Flue gas mass flow rate (oil)	kg/h	1.5 x combustion output in kW					
Total length (dimension g)	mm	1586	1586	1586	1666	1586	1486
Total width (dimension f)	mm	1238	1288	1442	1442	1542	1672
Total height (dimension e)	mm	1976	2122	2262	2387	2527	2602
Weight when empty incl. thermal insulation	kg	534	626	745	800	866	1005
Water content	m ³	0.20	0.23	0.29	0.34	0.34	0.42
Flue gas volume	m ³	0.27	0.34	0.41	0.4	0.53	0.54
Flow and return connections	DN/PN	150/40	150/40	200/25	200/25	200/25	250/25
Drain on the water side	G	½					
Drain on the gas side	R	½					
Female connections	R	½					
Flue gas connection, external	Ø mm	410	460	510	560	610	660
Flue gas connection, internal	Ø mm	400	450	500	550	600	650

Specification Vitotrans 200-LW for Vitomax 200-LW M62A

Rated boiler heating output	kW	2300	2800	3500	4500	6000	
Rated heating output AWT (gas) ^{*9}	kW	89	103	139	167	241	
Rated heating output AWT (fuel oil EL) ^{*9}	kW	81	95	127	153	220	
Permissible operating pressure	bar	16					
Permissible flow temperature	°C	120					
Permissible return temperature	°C	65 ^{*5}					
Pressure drop on the water side	mbar	174	174	174	175	176	
Pressure drop on the flue gas side (gas) ^{*6}	Pa	118	101	122	190	209	
Pressure drop on the flue gas side (fuel oil EL) ^{*6}	Pa	106	91	110	171	188	
Flue gas mass flow rate (gas)	kg/h	1.5225 x combustion output in kW					
Flue gas mass flow rate (fuel oil EL)	kg/h	1.5 x combustion output in kW					
Total length (dimension g)	mm	1586	1486	1586	1586	1666	
Total width (dimension f)	mm	1238	1292	1442	1442	1672	
Total height (dimension e)	mm	2191	2317	2487	2582	2742	
Weight when empty incl. thermal insulation	kg	534	573	745	746	1005	
Water content	m ³	0.20	0.19	0.29	0.29	0.42	
Flue gas volume	m ³	0.27	0.35	0.41	0.41	0.54	
Flow and return connections	DN/PN	150/40	150/40	200/25	200/25	250/25	
Drain on the water side	G	½					
Drain on the gas side	R	½					
Female connections	R	½					
Flue gas connection, external	Ø mm	410	460	510	560	660	
Flue gas connection, internal	Ø mm	400	450	500	550	650	

^{*8} Heating output of the Vitotrans 200-LW at a flue gas inlet temperature of 203 °C (HEL) or 214 °C (gas) and system temperatures of 90/70 °C

^{*5} Never let the temperature fall below the dew point temperature of the flue gas.

^{*6} Pressure drop on the hot gas side at rated heating output. The burner must be able to overcome the hot gas pressure drop of the boiler and the Vitotrans 100/200-LW.

^{*9} Heating output of the Vitotrans 200-LW at a flue gas inlet temperature of 182 °C (HEL) or 188 °C (gas) and system temperatures of 90/70 °C

Flue gas/water heat exchanger Vitotrans 100-LW, Vitotrans 200-LW (cont.)

Dimensions

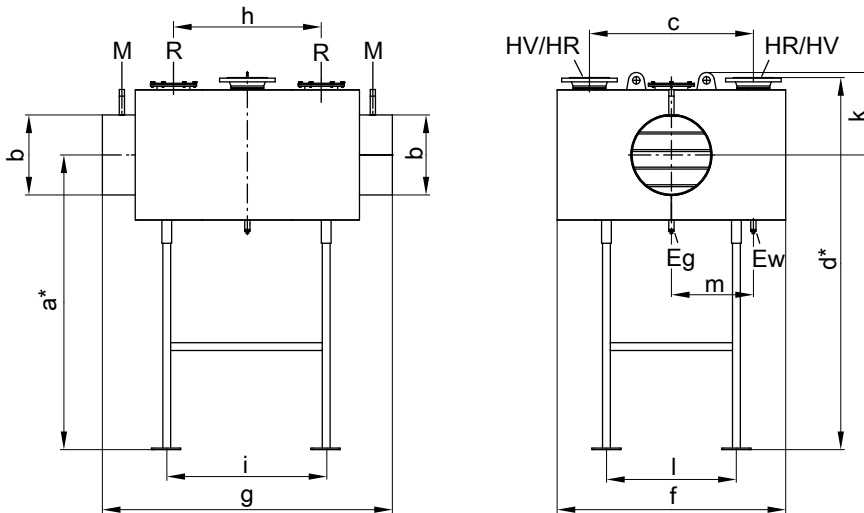

Vitotrans 100/200-LW

Ew Drain connector on the water side
 Eg Drain connector on the gas side
 HR Heating water return
 HV Heating water flow

R Cleaning aperture (159 Ø mm internal)
 M Female connections G ½
 * Dimension varies; see table

Dimensions

Boiler output		kW	2300	2800	2900	3500	4200	4500	5000	6000
Vitotrans 100-LW	a min.	mm	1435	1730	1535	1630	1755	1950	1850	1925
	a max.	mm	1800	1880	1685	2005	1905	2100	2000	2215
	b	mm	410	460	460	510	560	560	610	660
	c	mm	840	840	940	940	940	940	990	1100
	d min.	mm	1879	2174	1979	2079	2249	2444	2344	2481
	d max.	mm	2244	2324	2129	2454	2399	2594	2494	2771
	g	mm	1408	1408	1408	1408	1408	1408	1408	1408
	f	mm	1236	1229	1335	1375	1375	1382	1425	1599
	h	mm	679	508	658	658	658	658	658	658
	i	mm	750	750	750	750	750	750	750	750
	k	mm	466	466	466	466	512	512	512	557
	l	mm	670	672	770	720	720	722	770	824
	m	mm	420	420	500	475	475	475	500	550
Vitotrans 200-LW	a min.	mm	1435	1730	1535	1630	1755	1950	1850	1925
	a max.	mm	1800	1880	1685	2005	1905	2100	2000	2215
	b	mm	410	460	460	510	560	560	610	660
	c	mm	840	890	890	990	990	990	1090	1190
	d min.	mm	1879	2219	2024	2169	2295	2490	2434	2526
	d max.	mm	2244	2369	2174	2544	2445	2640	2584	2816
	g	mm	1586	1486	1586	1586	1666	1586	1586	1666
	f	mm	1238	1292	1288	1442	1442	1442	1542	1672
	h	mm	840	750	840	840	920	840	840	920
	i	mm	928	828	928	928	1008	928	928	1008
	k	mm	466	512	512	557	557	557	602	602
	l	mm	666	716	716	766	766	766	866	916
	m	mm	420	470	445	495	495	495	545	625

Flue gas/water heat exchanger Vitotrans 100-LW, Vitotrans 200-LW (cont.)

Shipping dimensions and weights

Boiler output		kW	2300	2800	2900	3500	4200	4500	5000	6000
Vitotrans 100-LW	Length	mm	1408	1408	1408	1408	1408	1408	1408	1408
	Width	mm	1236	1229	1335	1375	1375	1382	1425	1599
	Height	mm	1564	1643	1567	1772	1652	1831	1727	1885
	Weight	kg	420	490	447	494	548	535	565	718
Vitotrans 200-LW	Length	mm	1586	1586	1586	1586	1586	1586	1586	1586
	Width	mm	1238	1292	1288	1442	1442	1442	1542	1672
	Height	mm	1564	1606	1606	1696	1696	1773	1788	1852
	Weight	kg	534	573	626	745	800	746	866	1005

Delivered condition

Flue gas/water heat exchanger for oil and gas operation for Vitomax 100-LW type M148 and Vitomax 200-LW type M62A:

- Thermal insulation fitted
- Height-adjustable frame

- Flue gas temperature sensor G ½ (lead length 6 m)
- Mating flanges on the water side

All components are individually packed and marked.

On-site tasks

- Fit the flue gas/water heat exchanger to the boiler
- Make the flue gas connections and pipework connections
- Weld the plinth to the flue gas/water heat exchanger
- Install the flue gas temperature sensor
- Fit the flange or compensator to the connection on the flue gas side of the boiler (see Vitomax accessories)
- Install the boiler coding card (see pack supplied with heat exchanger)

The Vitotrans 100/200-LW is installed downstream of the boiler. Keep the areas in front of inspection ports, lateral connectors and other fitted components free.

Tested quality

 CE designation according to current EC Directives.

9.1 Product description

Vitotrans 300 flue gas/water heat exchanger for the following Vitomax boilers:

- Vitomax 100-LW
With 0.65 to 6.0 MW rated heating output.
- Vitomax 200-LW
With 2.3 to 6.0 MW rated heating output.
- Vitomax 300-LT
With 1.86 to 5.9 MW rated heating output.

Benefits

- High operational reliability and a long service life due to corrosion-resistant stainless steel. Stainless steel 1.4571 is suitable for gas operation and for short-term use with fuel oil EL in dual fuel operation; stainless steel 1.4539 is for constant operation with fuel oil EL for the utilisation of condensing technology.
- Compact design – space saving for installation directly behind the boiler.
- Easy hydraulic connection – either the entire flow rate or, to optimise the utilisation of condensing technology, a part of the water volume can be routed through the Vitotrans 300.

- Vitotrans 300 flue gas/water heat exchanger with Inox-Tubal heating surface up to 6 MW.
- Vertical Inox-Tubal heating surfaces for high operational reliability and long service life.
- Highly effective heat transfer and high condensation rate.
- Neutralising systems matched to the Vitotrans 300 flue gas/water heat exchangers are available.

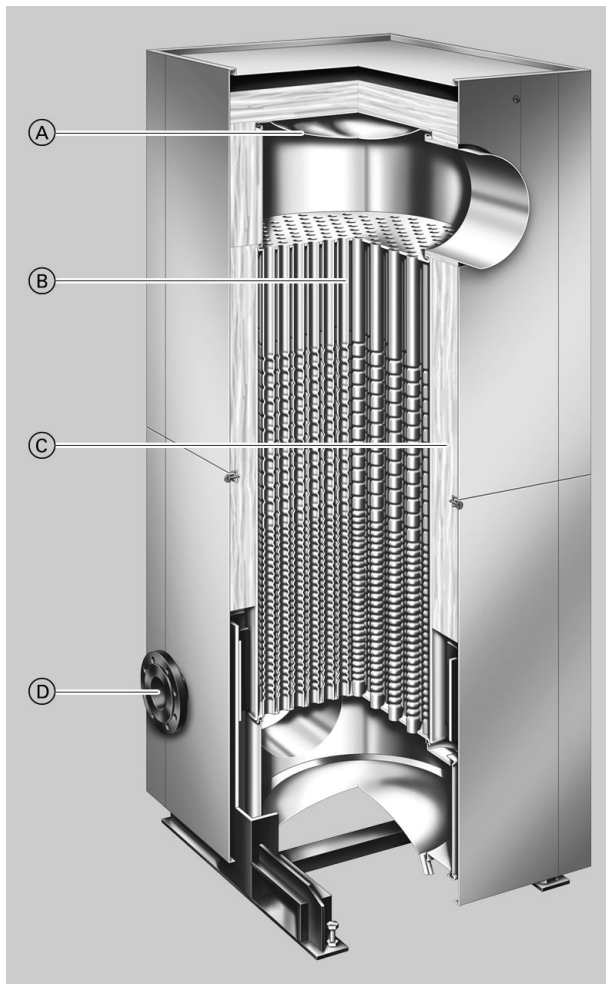

- Ⓐ Cleaning aperture
- Ⓑ Inox-Tubal heating surfaces made from stainless steel
- Ⓒ Thermal insulation
- Ⓓ Heating water return (inlet)

Delivered condition

Heat exchanger body with fitted lower flue gas collector and integral feet. Mating flanges are fitted to all connectors.

- Two crates with thermal insulation
- One crate with the upper flue gas collector

- One crate with offset flue adaptor
- One box with collar

Tested quality

CE CE designation according to current EC Directives at a permissible flow temperature (safety temperature) of up to 110 °C to EN 12828.

9.2 Specification
Specification

Boiler size		1	2	3	4	5	6
Vitomax 100-LW rated heating output	MW	2.3	2.9	3.5	4.2	5.0	6.0
Matching Vitotrans 300 for 6 bar							
– Gas operation	Part no.	Z008 087	Z008 088	Z008 089	Z008 090	Z008 091	Z008 092
– Oil operation	Part no.	Z008 257	Z008 259	Z008 261	Z008 263	Z008 065	Z008 267
Permiss. operating pressure	bar	6	6	6	6	6	6
Permiss. flow temperature (safety temperature)	°C	110	110	110	110	110	110
Heat exchanger weight	kg	690	690	920	1050	1050	1270
Matching Vitotrans 300 for 10 bar							
– Gas operation	Part no.	Z008 241	Z008 242	Z008 243	Z008 244	Z008 245	Z008 246
– Oil operation	Part no.	Z008 258	Z008 260	Z008 262	Z008 264	Z008 266	Z008 268
Permiss. operating pressure	bar	10	10	10	10	10	10
Permiss. flow temperature (safety temperature)	°C	110	110	110	110	110	110
Heat exchanger weight	kg	740	970	970	1100	1100	1320

Boiler size		1	2	3	4	5
Vitomax 200-LW rated heating output	MW	2.3	2.8	3.5	4.5	6.0
Matching Vitotrans 300 for 6 bar						
– Gas operation	Part no.	Z008 082	Z008 083	Z008 084	Z008 085	Z008 086
– Oil operation	Part no.	Z008 247	Z008 249	Z008 251	Z008 253	Z008 255
Permiss. operating pressure	bar	6	6	6	6	6
Permiss. flow temperature (safety temperature)	°C	110	110	110	110	110
Heat exchanger weight	kg	690	920	920	1050	1270
Matching Vitotrans 300 for 10 bar						
– Gas operation	Part no.	Z008 236	Z008 237	Z008 238	Z008 239	Z008 240
– Oil operation	Part no.	Z008 248	Z008 250	Z008 252	Z008 254	Z008 256
Permiss. operating pressure	bar	10	10	10	10	10
Permiss. flow temperature (safety temperature)	°C	110	110	110	110	110
Heat exchanger weight	kg	740	970	970	1100	1320

Boiler size		1	2	3	4	5	6	7
Vitomax 300-LT rated heating output	MW	1.86	2.3	2.9	3.5	4.1	4.7	5.9
Matching Vitotrans 300 for 6 bar								
– Gas operation	Part no.	Z000 744	Z000 745	Z000 746	Z000 747	Z000 748	Z000 749	Z000 750
– Oil operation	Part no.	Z000 758	Z000 759	Z000 760	Z000 761	Z000 762	Z000 763	Z000 764
Permiss. operating pressure	bar	6	6	6	6	6	6	6
Permiss. flow temperature (safety temperature)	°C	110	110	110	110	110	110	110
Heat exchanger weight	kg	690	690	920	920	1050	1050	1270
Matching Vitotrans 300 for 10 bar								
– Gas operation	Part no.	Z000 751	Z000 752	Z000 753	Z000 754	Z000 755	Z000 756	Z000 757
– Oil operation	Part no.	Z000 765	Z000 766	Z000 767	Z000 768	Z000 769	Z000 770	Z000 771
Permiss. operating pressure	bar	10	10	10	10	10	10	10
Permiss. flow temperature (safety temperature)	°C	110	110	110	110	110	110	110
Heat exchanger weight	kg	740	740	970	970	1100	1100	1300

Vitotrans 300 (cont.)

Boiler size		1	2	3	4	5	6	7
Matching Vitotrans 300 for 16 bar		on request						
Rated heating output range of the Vitotrans 300								
– Gas operation	from kW	177	219	276	333	390	447	561
	to kW	200	248	305	371	428	504	628
– Oil operation	from kW	121	150	189	228	267	306	384
	to kW	137	170	209	254	293	345	430
Pressure drop on hot gas side ^{*10}								
Vitotrans 200–LW	Pa	150	200	200	250	250	350	550
	mbar	1.5	2.0	2.0	2.5	2.5	3.5	5.5
Vitotrans 300–LT	Pa	100	150	150	200	200	250	500
	mbar	1.0	1.5	1.5	2.0	2.0	2.5	5.0
Flue gas mass flow rate in kg/h	Gas	1.5225 x combustion output in kW						
	Oil	1.5 x combustion output in kW						
Overall dimensions								
Total length (dimension g)	mm		1320		1450		1550	1650
Total width incl. mating flanges	mm		1280		1430		1520	1720
Total height (dimension a)	mm		2600		2810		3010	3210
Transport dimensions								
Length	mm		1239		1356		1444	1602
Width (dimension k), excl. mating flanges	mm		1170		1310		1390	1570
Height (dimension b)	mm		2509		2719		2923	3124
Content								
Heating water	l		430		500		630	750
Flue gas	m ³		0.661		1.040		1.402	1.876
Connections								
Heating water flow and return	PN 16 DN		150		200		200	250
Condensate drain	R		1¼		1¼		1¼	1¼
Flue gas connection	DN		500		600		700	800

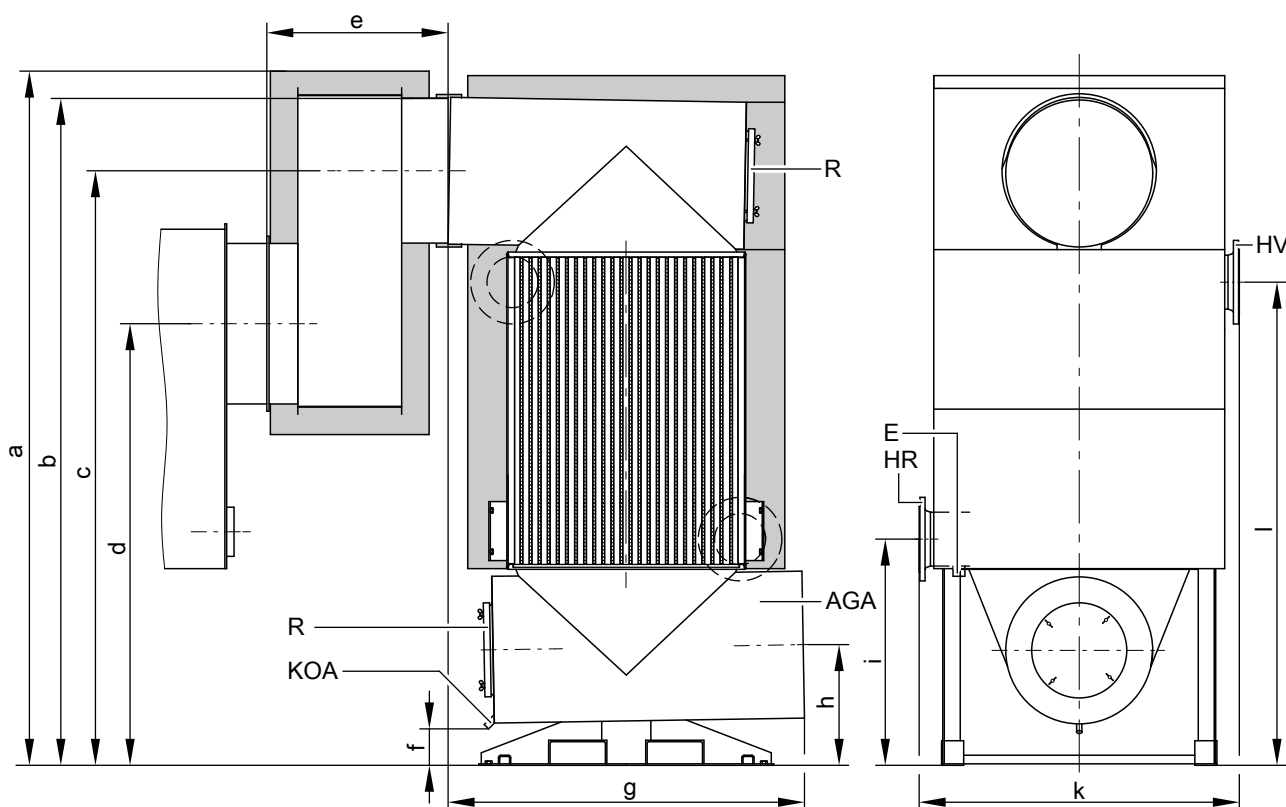
Table of dimensions Vitotrans 300 for Vitomax 100-LW

Part no.		Z008 087	Z008 088	Z008 089	Z008 090	Z008 091	Z008 092
		Z008 257	Z008 259	Z008 261	Z008 263	Z008 265	Z008 267
		Z008 241	Z008 242	Z008 243	Z008 244	Z008 245	Z008 246
		Z008 258	Z008 260	Z008 262	Z008 264	Z008 266	Z008 268
a	mm	2634	2844	2847	3049	3045	3249
b	mm	2543	2753	2756	2958	2958	3158
c	mm	2280	2440	2443	2595	2595	2745
d	mm	1510	1610	1705	1830	1925	2000
e	mm	580	660	660	710	810	815
f	mm	135	136	139	139	139	138
g	mm	1320	1450	1450	1542	1542	1646
h	mm	442	495	498	550	550	600
i	mm	801	932	935	1035	1035	1159
k	mm	1161	1303	1303	1387	1387	1570
l	mm	1893	1973	1976	2080	2080	2154

Table of dimensions Vitotrans 300 for Vitomax 200-LW

Part no.		Z008 082	Z008 083	Z008 084	Z008 085	Z008 086
		Z008 247	Z008 249	Z008 251	Z008 253	Z008 255
		Z008 236	Z008 237	Z008 238	Z008 239	Z008 240
		Z008 248	Z008 250	Z008 252	Z008 254	Z008 256
a	mm	2632	2842	2842	3047	3267
b	mm	2541	2751	2751	2956	3178
c	mm	2278	2438	2438	2593	2765
d	mm	1725	1805	1930	2025	2140
e	mm	550	660	660	710	812
f	mm	133	134	137	137	158
g	mm	1320	1450	1450	1542	1646
h	mm	440	493	493	548	620
i	mm	799	930	930	1032	1179
k	mm	1161	1303	1303	1387	1570
l	mm	1891	1971	1971	2077	2174

Vitotrans 300 (cont.)

Table of dimensions Vitotrans 300 for Vitomax 300-LT

Part no.		Z000 744	Z000 745	Z000 746	Z000 747	Z000 748	Z000 749	Z000 750
		Z000 751	Z000 752	Z000 753	Z000 754	Z000 755	Z000 756	Z000 757
		Z000 758	Z000 759	Z000 760	Z000 761	Z000 762	Z000 763	Z000 764
		Z000 765	Z000 766	Z000 767	Z000 768	Z000 769	Z000 770	Z000 771
a	mm	2600	2600	2810	2810	3010	3045	3250
b	mm	2509	2509	2719	2719	2923	2968	3164
c	mm	2260	2260	2420	2420	2575	2610	2765
d	mm	See boiler datasheet						
e	mm	550	580	660	660	710	740	815
f	mm	131	131	132	132	135	135	133
g	mm	1320	1320	1450	1450	1550	1550	1650
h	mm	438	438	491	491	546	546	597
i	mm	791	791	920	920	1024	1024	1149
k	mm	1170	1170	1310	1310	1390	1390	1570
l	mm	1883	1883	1966	1966	2070	2070	2145

Pressure drop on the heating water side

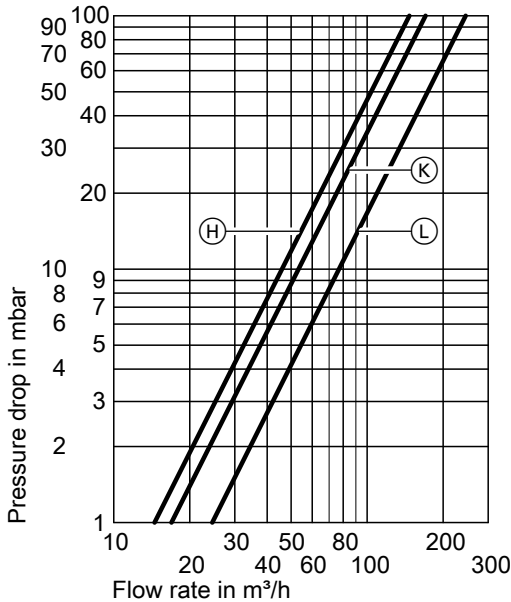

Part no.

Z000 744 and Z000 745
Z000 751 and Z000 752
Z000 758 and Z000 759
Z000 765 and Z000 766
Z008 082 and Z008 236
Z008 247 and Z008 248

Curve

(H)

Z000 746 to Z000 749
Z000 753 to Z000 756
Z000 760 to Z000 763
Z000 767 to Z000 770

(K)

Z008 083, Z008 084, Z008 085
Z008 249, Z008 251, Z008 253
Z008 237, Z008 238, Z008 239
Z008 250, Z008 252, Z008 254

Z000 750
Z000 757
Z000 764
Z000 771
Z008 086
Z008 255
Z008 240
Z008 256

(L)

Output data for gas operation

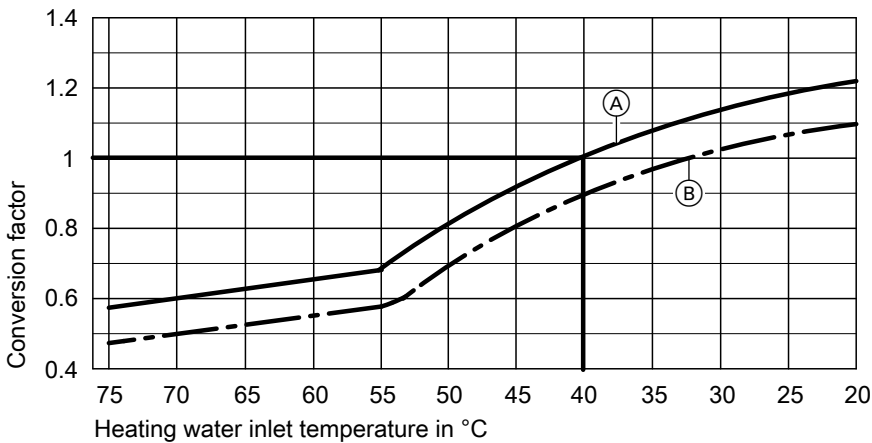

5822 427 GB (A) Vitomax 100
(B) Vitomax 200, Vitomax 300

Conversion of the output data

The heating output details for the Vitotrans 300 flue gas/water heat exchanger refer to a flue gas inlet temperature of 200 °C and a heating water inlet temperature into the heat exchanger of 40 °C.

For different conditions the heating output can be calculated by multiplying the specified rated heating output by the conversion factor established from the diagram.

Design information

10.1 Transport, delivery, handling and siting

Transportation of Vitomax boilers

Note

The relevant national regulations / regulations for the prevention of accidents or comparable laws / directives must be observed. Only use the marked fixing points.

1. Lifting the boiler
Use lifting eyes (A) or lifting points (C) (see arrows) on the boiler support.
2. Moving the boiler
Fit steel rollers underneath base rail (C).
3. Secure the pulling equipment to tie-down points (B).
Information regarding the transport weight can be found in the shipping documents or on the boiler type plate.

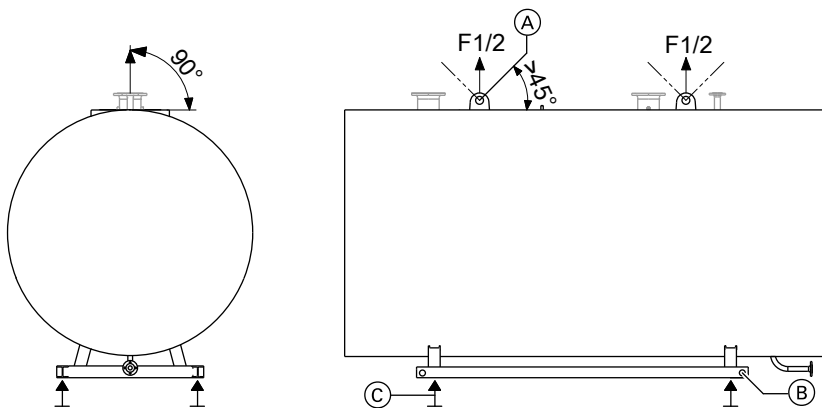

Schematic diagram

Storage of boilers before commissioning

During extended storage before the commissioning of the boiler, the following information must be observed:

- Vitomax and Vitoplex boilers must be stored in enclosed rooms, free from weather influences under dry conditions.
- The room temperature must not fall below 0 °C or exceed +50 °C.
- The flue gas side and the burner flange must be sealed.
In its delivered condition the boiler is protected as standard on the water side with dummy flanges or caps against the ingress of foreign matter.

- Remove the transport packaging to prevent the formation of condensate.
- To avoid corrosion in the unpressurised state during a storage period of more than 4 weeks, protect the interior of the boiler against moisture on the flue gas and water side with a desiccant, e.g. silica gel. The amount of desiccant depends on the boiler volume. Check the effectiveness of the desiccant regularly, observing the manufacturer's instructions. The desiccant must not come into contact with the boiler material, e.g. through suspended fixing. Preserve the dry flue gas side with a thin film of graphite or boiled oil. Instead of the moisture extraction on the flue gas side by means of a desiccant, a dryer with air circulation can also be connected.

Delivery

The delivery of the boiler system is to be individually agreed for each project. We recommend that transport routes, the required permits, the installation areas, special cranes etc. are clarified prior to delivery.

Handling and siting

Lifting eyes will be provided on each boiler and flue gas/water heat exchanger where lifting gear may be attached. Should additional or different lifting eyes be required due to local circumstances, please contact our sales engineers prior to placing the order. We will then develop a tailor-made solution.

Our experts can undertake the handling and siting on prepared foundations upon request (chargeable option).

The boilers can be installed on level foundations that are designed to support the operating weight of the boiler. Observe the max. installed burner height.

However, to facilitate the cleaning of the installation room it is appropriate to position the boiler on a plinth.

For recommended minimum clearances to walls for installation and maintenance work, see the datasheet of the relevant boiler.

Anti-vibration boiler supports may be used if anti-vibration measures are required.

Boiler room

Note

Vitomax boilers must be installed in enclosed spaces that are suitable as boiler rooms. Installation in the open, for example underneath a sloping roof, should only be undertaken following consultation with Viessmann.

Our warranty excludes damage resulting from the following:

- *Structural modifications to boiler, thermal insulation, boiler cover or boiler support.*
- *Introduction of forces or torque affecting the boiler or accessories.*
- *Failure to observe the general operating conditions.*
- *Incorrect storage, transport or handling.*

General boiler room requirements:

- Avoid air contamination through halogenated hydrocarbons (e.g. as in sprays, paints, solvents and cleaning agents)
- Avoid very dusty conditions
- Avoid high levels of humidity
- Prevent frost and ensure good ventilation

In rooms where air contamination through **halogenated hydrocarbons** can occur, install the boilers and flue gas/water heat exchangers only if adequate measures can be taken to provide a supply of uncontaminated combustion air.

Failure to observe these instructions will result in a loss of warranty rights.

Shutting down the system

To prevent corrosion setting in during idle periods when the boiler is not pressurised, preserve the boiler surfaces on the flue gas and water sides subject to the length of the period during which the boiler is taken out of use. There is a differentiation between wet preservation (during which exposure to oxygen is to be avoided) and dry preservation (during which moisture levels are to be minimised).

Brief interruption of operation (1 to 2 days)

Water side

Recommendation: Maintain the boiler pressure and temperature. If this is not possible and the boiler needs to be depressurised for several days, we recommend the following:

To prevent oxygen corrosion, approx. one hour before shutting the boiler down, add 2 to 3 times more oxygen binder than usual to the feedwater until the boiler is shut down.

Flue gas side

Keep the heating surfaces dry. Remove severe contamination as it can bind moisture.

Longer interruption of operation

Water side

Wet conservation, as long as there is no risk of frost

Fill the boiler up to the highest possible level with treated feedwater. To prevent oxygen corrosion, add an oxygen binder to the boiler water (e.g. sodium sulphite) in accordance with the manufacturer's instructions. Test the oxygen binder concentration at least monthly and top up if required. For this, ensure good admixing with the boiler water (thermal or mechanical agitation).

In multi boiler systems, if only some boilers must be preserved, these can be filled with desalinated boiler water from the boilers that remain in use. This will also maintain the temperature.

Maintaining pressure in a fully filled boiler using nitrogen (preferably nitrogen 5.0) of 0.1 to 0.2 bar can prevent corrosion.

Dry preservation if there is a risk of frost or prolonged idle period

Drain the boiler at 90 °C and then open the water connections.

Dry the boiler thoroughly and fill with desiccant (e.g. silica gel) in accordance with the manufacturer's details.

Ensure that the desiccant does not come into contact with the boiler material.

Then close the boiler again.

Check at regular intervals whether the desiccant is still able to absorb moisture.

Flue gas side

Thoroughly clean and dry the surfaces on the flue gas side.

Maintain the alkaline balance of the wash water (pH 8-9, in the case of ammonia pH 10).

After thoroughly drying the surfaces, preserve them with a thin film of graphite or varnish.

Keep the surfaces dry during the idle periods (by adding a desiccant such as silica gel or by air circulation via a connected dryer).

Further details

For further details, see the operating instructions for preservation on the water and hot gas side or the VdTÜV datasheets (no. 1465, Oct. 1978) and the VGB (no. R116H, 1981) [or local regulations].

Requirements of the Muster-Feuerungsverordnung [Sample Combustion Ordinance - Germany]

The installation room must meet the standards laid down by the "Muster Feuerungsverordnung" [Germany]. Observe the building regulations and combustion equipment ordinances of the relevant country of installation.

Combustion air supply

For open flue combustion equipment with a total rated heating output in excess of 50 kW, the combustion air supply is deemed to have been verified if the combustion equipment is located in areas which provide an aperture or duct leading outdoors.

At 50 kW rated heating output, the cross-section of the aperture must be at least 150 cm². For every kilowatt rated heating output in excess of 50 kW, the aperture must be 2 cm² larger than stated above.

Pipes must be sized to provide equivalent flow rates. The required cross-section may be split over a maximum of 2 apertures or pipes.

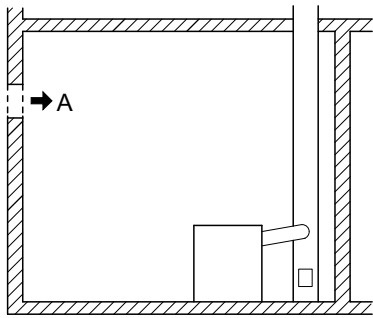

$$A = 150 \text{ cm}^2 + 2 \frac{\text{cm}^2}{\text{kW}} \times \Sigma \dot{Q}_n - 50 \text{ kW}$$

$\Sigma \dot{Q}_n$ = sum of all rated heating outputs in kW

Combustion air apertures and pipes must not be closed or blocked if installed safety equipment cannot adequately ensure that the combustion equipment can only be operated when the aperture is open. The required cross-section must not be blocked by any closure or grille.

Load-bearing boiler cover

Vitomax boilers are delivered with a load-bearing fitted boiler cover.

Modular boiler control platform

A modular boiler control platform is available as an option and is available for all Vitomax boilers from a crown height of 2 metres. For dimensions, see the control platform datasheets.

10.2 System design

Flow temperatures

To minimise distribution losses, we recommend that you size the heat distribution system and the DHW heating to a max. flow temperature of 70 °C.

For boilers supplied with a boiler control unit, the max. boiler water temperature is limited to 85 °C. The flow temperature may be increased by adjusting the thermostat.

Safety temperatures

- Permiss. flow temperatures (= safety temperatures):
110 °C to EN 14394 and EN 12828
120 °C to EN 14394 and EN 12953
- Recommended flow temperature:
Approx. 15 K below the safety temperature

- High limit safety cut-out of the boiler control unit:
Factory setting 110 °C
Adjustable to 100 °C

Selection of rated heating output

Select boilers according to the required heat load. The efficiency of low temperature and condensing boilers is stable in a wide range of boiler loads.

Therefore, the heating output for low temperature boilers, condensing boilers and multi boiler systems may be higher than the calculated heat load of the building in question.

Emergency stop switch

It must be possible to switch off the burner, fuel supply equipment and combustion equipment control units at any time by means of an emergency stop switch located outside the installation room.

Provide a sign adjacent to the emergency stop switch with the inscription "EMERGENCY STOP SWITCH - COMBUSTION".

Safety precautions

For gas combustion equipment, fuel lines **must** be equipped with the following safety equipment immediately upstream of the gas combustion equipment:

- The fuel supply must automatically shut off in case of an external thermal load in excess of 100 °C.
- Up to a temperature of 650 °C and over a period of at least 30 min, not more than 30 l/h (measured as air flow rate) must be able to flow through or out of the fuel line.

Combustion equipment must be installed far enough away from combustible materials and built-in furniture or be shielded from such material/furniture, so that at the rated heating output of the combustion equipment, no temperatures exceeding 85 °C will occur. Alternatively, maintain a distance of at least 40 cm.

Heating on board ships

Some special conditions must be observed if boilers are used to heat accommodation on board ships:

- On ships, the integrated products are subjected to substantial loads.
- Observe the special requirements specified by insurance underwriters – ship classification companies.
- Viessmann boilers cannot be used for every kind of application.

Earthing of Vitomax boilers

At the r.h. and l.h. side of the boiler support, Vitomax boilers are provided with facilities for attaching earth tabs.

Requirements through heat load

The requirements of EN 12831 on calculating the heat load are met by the weather-compensated control unit of the Vitomax 300-LT, type M343. To reduce the heat-up load, the night setback is reduced in the case of low outside temperatures. The flow temperature will be raised for a limited time to reduce the heat-up time after a setback phase.

Pressure maintaining systems

Every hot water boiler system must be provided with an expansion space that is able to accommodate the temperature-related changes in the water content of the hot water boiler system and the heat consumer system. For this, use a dedicated expansion vessel or a dedicated drip pan. The system and particularly the expansion vessel as well as any drip pan including their connection lines must be protected from frost. See also EN 12953 T6.

Sealed unvented systems – e.g. those equipped with a diaphragm expansion vessel – offer good protection against the ingress of air-borne oxygen into the system, if correctly sized and operating at the correct pressure.

At all points in the heating system, including on the intake side of the pump, the pressure must be higher than the pressure of the surrounding atmosphere in all operating states.

The pre-charge pressure of the diaphragm expansion vessel should be checked at least during the annual service.

Pump controlled pressure maintaining systems

In heating systems with automatic and in particular pump-controlled pressure maintaining systems with integral deaeration, we recommend the installation of a diaphragm expansion vessel (DEV) for each boiler as individual protection.

Boiler output in MW	Diaphragm expansion vessel Capacity in litres
up to 1	140
up to 2	300
up to 5	800
up to 10	1600

Failure to observe these recommendations may result in damage to the boiler or to other system components.

Furthermore ensure that only pump controlled pressure maintaining systems that are sealed against corrosion and protected against oxygen ingress into the heating water are used. Otherwise damage to the system through oxygen corrosion can result.

Pump controlled pressure maintaining systems with atmospheric deaeration through cyclical pressure release enable a central post-ventilation of the heating system, but do not represent a form of oxygen removal in the sense of corrosion protection to VDI 2035 sheet 2.

This reduces the frequency and level of pressure fluctuations. This contributes considerably to improved operational reliability and longer service life of the system components.

10.3 Water connection

Heating connections

Existing systems

Flush the heating system thoroughly before connecting the boiler to an existing heating system, to remove dirt and sludge residues. Otherwise, these dirt and sludge residues would be deposited in the boiler and could lead to local overheating, noise and corrosion. Boiler damage caused by such deposits is excluded from our warranty. Where necessary, install dirt traps.

Connections on the heating water side

Connect all heat consumers or heating circuits to the boiler flow and return connectors. Never make any connections to the safety flow or to other connections.

We recommend you install shut-off valves into the heating flow and return lines, so that the entire water content will not have to be drained, should work be required on the boiler or heating circuits.

Heating circuits

For heating systems with plastic pipes, we recommend the use of impermeable pipes to prevent the diffusion of oxygen through the pipe walls. Provide system separation in heating systems with plastic pipes (DIN 4726) that are permeable to oxygen. We supply a separate heat exchanger for this purpose.

Underfloor heating systems and heating circuits with a large water content should also be connected via mixers, if low temperature and ultra-low temperature boilers are used. These should be controlled via the Vitotronic 300-K or with a separate control unit, e.g. the Vitotronic 200-H.

Boiler circuit and shunt pumps

Vitomax boilers do not require pumps for forced circulation. For more detailed information, see system examples.

The use of a shunt pump has proven beneficial for boilers or individual cases where a return temperature raising facility (RTRF) is required. This is sized to approx. 35 % of the total pump rate. See also page 8 system pack M148. The shunt pump is only in operation when the minimum return temperature^{*11} is not achieved. Use an RTRF in cases where the specified return temperatures must be safeguarded.

*11 See boiler operating conditions.

Design information (cont.)

For this, two systems are available:

- RTRF with shunt pump
- RTRF with boiler circuit pump and 3-way mixing valve

Resulting benefits are:

- Smaller pump, i.e. lower investment outlay
- Lower power consumption of the pump
- Shorter runtimes of the shunt pump
- Reduced electricity bills

Heating circuit pumps

Heating circuit pumps in heating systems with rated heating output > 25 kW must be equipped or designed so that the power consumption is matched automatically to the pump rate required by the operation in at least three stages, subject to there not being any safety concerns relating to the boiler.

System examples

See separate technical guide.

10.4 Safety equipment for hot water boilers

The EN 12828 applies to the design of hot water heating systems with safety temperatures up to 110 °C. Observe EN 12953 for water heating systems with safety temperatures > 110 °C. This standard contains safety requirements laid down for boilers and boiler systems.

Safety equipment to EN 12828^{*12}

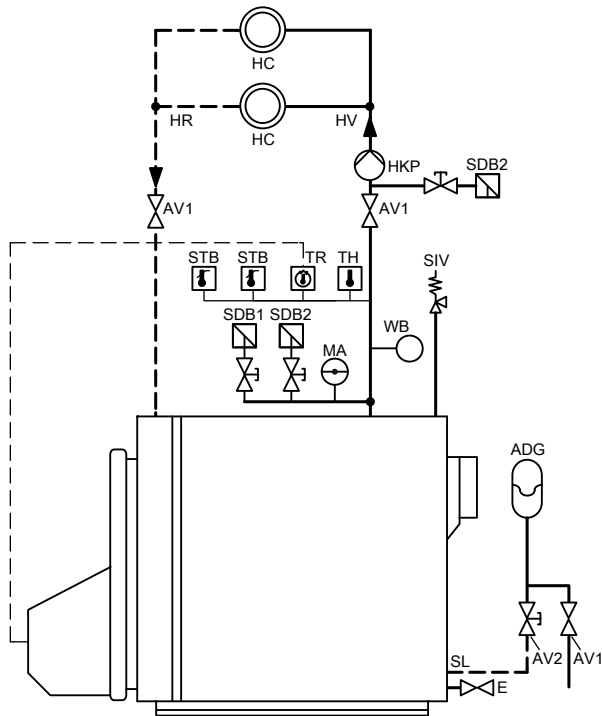

Safety equipment to EN 12953

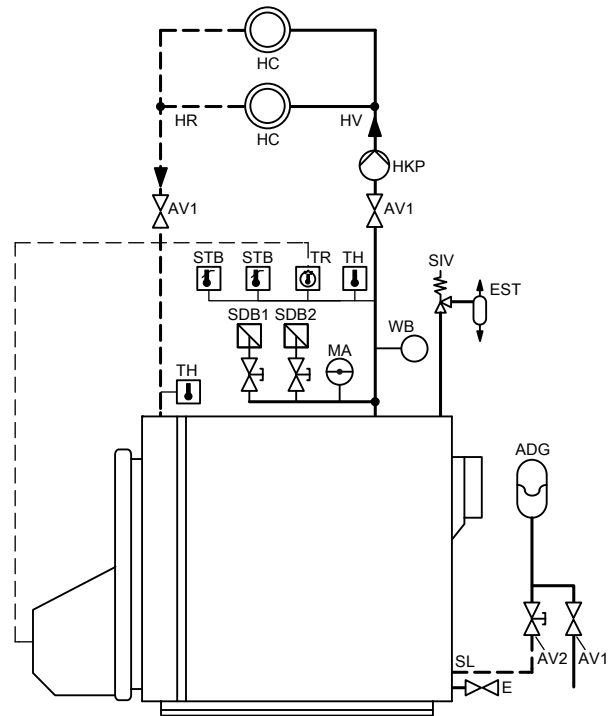

Required safety equipment

- ADG Sealed expansion vessel^{*13}
- AV1 Shut-off valve
- AV2 Shut-off valve with protection against unintentional closing, e.g. cap valve
- E Drain
- EST Flash trap
- MA Pressure gauge
- SDB1 Safety pressure limiter max.
- SDB2 Safety pressure limiter min.
- SIV Safety valve
- SL Safety expansion line
- STB High limit safety cut-out
- TH Thermometer
- TR Temperature controller
- WB Water level limiter

Further legends

- HC Heating circuit
- HKP Heating circuit pump
- HR Heating water return
- HV Heating water flow

The graphic "Safety equipment to EN 12828" shows the alternative measure for the flash trap with additional high limit safety cut-out and SDB1.

^{*12} Single boiler system without flash trap

^{*13} Shown as an example for maintaining the pressure

Design information (cont.)

General information

Low water indicator

EN 12828 specifies that boilers > 300 kW must be equipped with a low water indicator. Tests must verify that the burner will be automatically switched off in the event of water shortage due to a leak in the heating system and simultaneous burner operation, before the boiler or the flue system reach unacceptably high temperatures.

Maximum pressure limiter

Required for every boiler in a system in case the rated heating output of the boiler exceeds 300 kW.

Minimum pressure limiter

One required per system to EN 12828 and one per boiler to EN 12953-6.

Safety valve

Equip the boilers to EN 12828 with a type-tested safety valve. The connection line between the boiler and the safety valve may not be fitted with shut-off devices. No pumps, fittings or constrictions may be present in this line.

Install the safety valves in an accessible area on the heat source or in its immediate vicinity in the flow pipe; there must not be any shut-off facility between the boiler and the safety valve. The cross-section of the supply line must not be smaller than the cross-section at the inlet to the safety valve. The pressure drop in the connection line must not exceed 3 % of the test pressure of the safety valve.

Flash trap

For boilers above 300 kW, install a flash trap with discharge pipe and drain line near the safety valve. The discharge pipe must lead outdoors. Any extracted steam must not endanger anyone.

The discharge pipe on the safety valve should be constructed so as to prevent the possibility of increases in pressure. Arrange the outlet of the drain line so that any water expelled by the safety valve can be safely observed and drained off.

Flash trap replacement

This alternative only applies up to 300 kW - see EN 12828, 4.6.2.3. A flash trap and discharge pipe are not required if a second high limit safety cut-out and a second maximum pressure limiter are installed.

Safety accessories selection table

The following table lists the control equipment required for sealed unvented heating systems.

	System ^{*14}	Boilers ≤ 300 kW	Boilers > 300 kW	System	Boiler
Safety temperature	≤ 110°C to EN 12828			> 110°C to EN 12953	
High limit safety cut-out	–	1	1	–	1 ^{*15}
Control thermostat	–	1	1	–	1
Boiler thermometer	1	1	–	–	1 x flow 1 x return
Pressure gauge assembly	1	1	–	See EN 12953	1
Pressure gauge					
Fill and sampling valve	–	–	–	–	1
Safety valve	1	1	1	–	1
Low water indicator					
According to EN 12828, the low water indicator can be replaced by an additional min. pressure limiter.	1	–	–	–	1
Maximum pressure limiter	1	1	–	–	1
Minimum pressure limiter	1	–	–	1 or	1
Flash trap	1	–	–	–	1
or					
According to the EN 12828, the flash trap is not required, if an additional high limit safety cut-out and a safety pressure limiter (maximum pressure limiter) are installed.					
High limit safety cut-out	(1)	–	–	–	–
Safety pressure limiter (maximum pressure limiter)	(1)	–	–	–	–

Note

If a boiler is operated at a safety temperature of > 110 °C, it must be supervised in accordance with the Health & Safety at Work Act [Germany]. Components with a safety function must have fail-safe operation, as well as redundancy, heterogeneity and self-monitoring. Accessories for safety temperatures of 120 °C are available. Further information is available in EN 12953.

10.5 Fuels

Vitomax boilers are suitable for the combustion of the following fuels:

- Fuel oil EL to DIN 51 603
- Biodiesel to DIN EN 51603-6, EN 14213, EN 14214 (or equivalent)
- Heavy fuel oil to DIN 51603 but exclusively to Vitomax 200-LW on request.

- Natural gas, town gas and LPG according to DVGW Code of Practice G 260/I and II [Germany] or local regulations.
- Biogas and sewer gas (alternative fuels on request):
Operation with biogas/sewer gas is possible under certain circumstances. **Special operating conditions** apply, as these gases generally contain sulphur compounds (the composition of which can fluctuate considerably) and other aggressive gases.

^{*14} Upstream of the first shut-off valve, as close as possible to the heat source

^{*15} To TRD BosB (operation without supervision) 72h 2 pce

Design information (cont.)

- The gas must be free from halogenated chlorinated hydrocarbons.
- For all operating conditions, the minimum return temperature should be above 65 °C. This requires an effective return temperature raising facility to be installed.
- Maintain the boiler in constant standby mode; night or weekend shutdowns are not permissible.
- The service intervals may be reduced on account of the fact that biogas is frequently impure. Regularly clean and service the boiler.

10.6 Burners

Suitable burners

Suitable burners are oil, gas or dual fuel burners designed as pressure-jet burners. The boiler-burner combination should be technically matched (emissions requirements, combustion chamber geometry). For dimensions of flame head length, flame tube length and diameter, see the boiler datasheets. The burners must comply with current directives and standards and must be identified accordingly. The use of alternative burner types (e.g. rotary atomisers) may require structural boiler modifications.

Pressure-jet oil burner

The burner must be tested and designated to EN 267.

Pressure-jet gas burner

The burner must be tested to EN 676 and CE-designated in accordance with Directive 2009/142/EC.

Unit burner

Matching boiler-burner Units are available subject to boiler type and fuel as well as the required emission values. See system packs.

Burner versions

We recommend the exclusive use of modulating burners from 2 MW.

Applications

The boiler operates with positive pressure in the combustion chamber. Use a burner that is suitable for the pressure drop on the hot gas side (see the datasheet for the boiler concerned).

Note the additional pressure drop of these appliances when using flue gas/water heat exchangers.

This also applies to alternative fitments in the flue (e.g. silencers, flue gas dampers), if these have not already been taken into consideration in the sizing of the flue system.

The burner is secured by means of a burner plate that is bolted to the boiler flange.

Burner adjustment

Set the maximum burner oil or gas throughput so that the specified maximum boiler heating output will not be exceeded. With modulating or multi stage burners observe that the flue system must be suitable for the lower flue gas temperatures resulting in the partial load operation.

When operating the Vitomax boiler with Vitotronic control units, maintain the minimum heating output specified under the respective operating conditions.

10.7 Flue gas routing

Requirements in accordance with the Sample Combustion Order [Germany]

Observe the specific Building Regulations and Fire Regulations in your country. We recommend you seek advice from your local flue gas inspector.

1. The flue system must be sized in accordance with the internal cross-section and height and if required also according to the thermal resistance and the internal surface to ensure that the flue gases will be extracted to the outside under all operating conditions and so that no dangerous pressures can be created in any rooms.
2. Flue gases from combustion equipment fired by liquid or gaseous fuels must be piped into chimney stacks or flue pipes.
3. For outlets from chimneys in combustion systems, the following conditions apply:
 - For roofs with a slope of up to 20° inclusive, the outlets must be at least 40 cm higher than the roof ridge or be at least 1m away from the roof surface.
 - For roofs with a slope of more than 20°, the outlets must be at least 40 cm higher than the roof ridge or have a horizontal clearance from the roof surface of at least 2 m and 30 cm.
 - For combustion systems with a total heating output of up to 50 kW, the outlets must be at least 1 m higher than the edges of ventilation apertures, windows or doors within a radius of 15 m; the radius increases by 2 m for every 50 kW begun, up to a maximum of 40 m.
4. As an alternative to section 3, for combustion systems with a combustion heating output of 1 MW or more, the height of the outlet must be at least 3 m above the highest point of the roof ridge and at least 10 m above ground level.

With a roof slope of less than 20°, relate the height of the boiler flue connection to a fictitious roof ridge, the height of which should be calculated on the assumption of a roof slope of 20°.
5. As an alternative to section 3, the flue gas from combustion systems with >10 MW should be routed away via one or more chimneys, the height of which should be calculated according to the regulations of the TA-Luft [Germany] of 24 July 2002.
6. For combustion systems with a combustion heating output > 20 MW:
 - Observe the TA-Luft regulations [Germany]; obtain an emission assessment.
 - Check with the appropriate local authority regarding regional requirements.
 - Emission assessments will be provided by approved institutes.
7. Provide a sufficiently large and easily accessible test port in the flue duct.

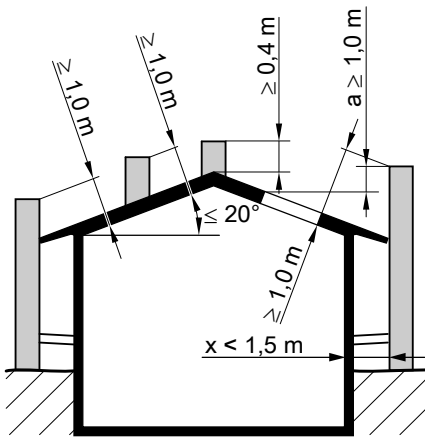

If $x < 1.5\text{ m}$, then $a \geq 1.0\text{ m}$

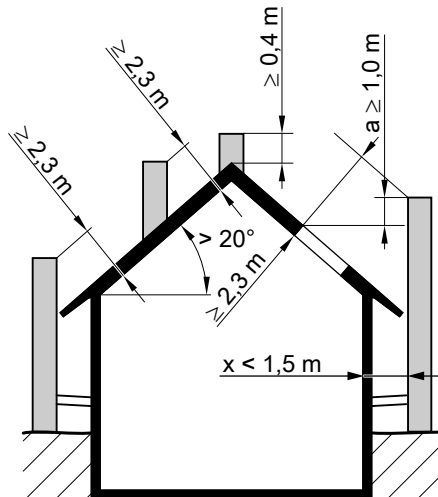

If $x < 1.5\text{ m}$, then $a \geq 1.0\text{ m}$

Sizing the flue system to EN 13384

Calculating the cross-sections of the flue system is a basic and essential requirement for the correct function of any flue system.

Standard values:

- Flue gas temperature at the back end of the boiler or downstream of the flue gas/water heat exchanger $140\text{ }^\circ\text{C}$ to $190\text{ }^\circ\text{C}$ at an ambient temperature of $15\text{ }^\circ\text{C}$ (see boiler or heat exchanger datasheet).
- The effective flue system height equals the height difference between the boiler outlet connector and the flue gas terminal.

- Length of the connection piece max. $\frac{1}{4}$ of the effective flue system height, but not more than 7 m . Same cross-section for connection piece and flue system.
- We recommend that flue gases enter the flue system at an angle of less than 45° .
- Plug-in flue systems are not recommended.

10.8 Sound insulation

The burner/boiler systems, circulation pumps and other drives used in heating systems generate noise. This noise is transferred from the installation room via floorboards, ceiling and walls to adjacent rooms and via the flue system as well as the ventilation air and extract air apertures into other rooms and into the open,

where it may be perceived as a nuisance. To avoid this happening, additional protective measures may be required which should be considered at the design stage. Subsequent measures to reduce noise development frequently require extensive effort and expenditure.

Attenuating airborne noise

Frequently, modern burners are equipped with silencer hoods or noise-attenuated ventilation air inlet housings. Additional silencer hoods may be used where more stringent anti-noise measures are required. These measures may be implemented later with minimum effort.

Silencer hoods are offered for various levels of sound insulation and are generally designed and built in accordance with specific system conditions (boiler type, fuel supply, building characteristics).

For larger systems it may be necessary to route the ventilation air through a sound-insulated channel, in order to avoid excess noise outside the building.

Flue gas silencers are generally only required where higher sound insulation measures are called for. Whether or not a flue gas silencer is required can be predicted only with some difficulty, because of the complexity of the creation and propagation of flame noise, the interaction between the burner, boiler and the flue system as well as the operating mode (flue system operating with positive or negative pressure).

It is advisable, therefore, to assess the noise emission into the neighbourhood in considering the sound power level measured at the flue system outlet point. Where flue gas silencers are required, allow for these during engineering. It is thus important that sufficient space for the flue gas silencer is available behind the boiler. The pressure drop on the flue gas side of the flue gas silencer is required for calculating the flue system to EN 13384, if it has not already been taken into consideration when sizing the burner.

Sound emissions

The sound level of a flame is at its highest in the low frequency range between 100 and 500 Hz . Experience tells us that the emission values in this frequency range lie between 100 and 115 dB (A) . Fluctuations depend on the different burner systems, flue system connections, fuels and other influences. Where specific requirements are specified for sound emissions, we recommend the installation of a dummy piece into the flue duct. The length of the dummy piece should at least correspond to the installed length of the flue gas silencer.

Insulation against structure-borne noise

Anti-vibration supports for the boiler are an economical and effective measure to reduce vibrations. Special sound-absorbing boiler supports are offered for this.

The boiler supports are designed to cope with the total weight in operation of the boiler. Ensure the supporting surface is level when using boiler supports.

Effective anti-vibration measures are particularly important when installing boilers in attics. Compensators may be used to physically separate the combustion equipment from the building.

These should be installed as near as possible to the boiler into the boiler flow, boiler return, safety pipe and flue. Also insulate any braces or brackets, if installed, against sound/vibration transmission to the building.

Detailed information for reducing noise emissions by combustion equipment in heating systems can be found in the Information Sheet No. 10 of the BDH (Bundesindustrieverband Deutschland Haus-, Energie- und Umwelttechnik e.V. [The Association of German domestic, energy and environmental industries]).

Sound insulation accessories

Viessmann supplies sound insulation accessories matched to the Vitomax boilers.

10.9 Standard values for water quality

The service life of any boiler as well as that of the complete heating system is influenced by the quality of the water.

The cost of a water treatment facility is certainly less than the cost of repairing damage to the heating system.

Observing the following requirements is necessary to safeguard your warranty rights. The manufacturer's warranty excludes damage due to corrosion and scaling.

The following is a summary of essential water quality requirements. A chemical water treatment can be ordered from Viessmann for filling.

Heating systems with rated operating temperatures up to 100 °C (VDI 2035)

Water used in heating systems must meet the chemical values in the Drinking Water Ordinance [Germany]. If well water or similar is used, check its suitability before filling the system.

Prevent excessive scale build-up (calcium carbonate) on the heating surfaces. For heating systems with operating temperatures up to 100 °C, the VDI Directive 2035 Sheet 1 "Prevention of heating system damage in hot water heating systems - scaling in DHW and hot water heating systems" applies [in Germany; check local regulations] with the following standard values. Please see the explanations in VDI Directive 2035 for further information.

Total heating output in kW	> 600
Total of alkaline earths mol/m ³	< 0.02
Total hardness in °dH	< 0.11

The standard values assume the following:

- The total volume of fill and top-up water will not exceed three times the water content of the heating system during its service life.
- The specific system volume is less than 20 l/kW heating output. In multi boiler systems, apply the output of the smallest boiler.
- All measures to prevent corrosion on the water side in accordance with VDI 2035 Sheet 2 have been implemented.

Softened the fill and top-up water in heating systems operating under the following conditions:

- The sum of alkaline earths in the fill and top-up water or the total hardness of the fill and top-up water exceeds the standard value.
- Higher fill and top-up water volumes are expected.

When engineering the system, observe the following:

- Install shut-off valves in different sections. This means that the entire heating water content will not have to be drained whenever the system needs repair or is extended.
- Install a water meter to record the amount of the fill and top-up water. Enter the volume of fill water and the water hardness into the boiler service instructions.

Operating information:

- Commission the system step by step, starting with the lowest boiler output and a high heating water flow rate. This prevents local concentration of limescale deposits on the heating surfaces of the boiler.
- During expansion or repair work, only drain the necessary sections.
- Where water treatment is required, treat even the first fill of the heating system prior to commissioning. This also applies to any subsequent filling, e.g. when adding top-up water or after a repair or after system expansion.
- Check, clean and activate filters, dirt traps and other blow-down or separating facilities in the heating water circuit more frequently after the commissioning or in case of new installations, later on subject to the water treatment applied (e.g. water softening).

The build-up of limescale deposits on the heating surfaces will be minimised if these instructions are observed.

Any damage to the hot water boiler because of a failure to observe the requirements to VDI Directive 2035, will in most cases already have caused a reduction in the service life of the installed heating appliance. Removing the limescale deposits is one option for restoring operational viability. This measure must be carried out by the Viessmann Industrieservice or a specialist company. Inspect the heating system for possible damage prior to returning it into use. It is essential that the faulty operating parameters are corrected to prevent renewed formation of excessive scale deposits.

The warranty becomes void through failure to observe VDI 2035 and EN 12953.

Heating systems with permissible flow temperatures in excess of 100 °C (VdTÜV DS 1466)

Operation with circulating water with low salt content

Use only water with low salt content as fill and top-up water.

Design information (cont.)

Operation with saline water

Wherever possible use water with a low salt content as fill and top-up water from which alkaline earths have been removed (softened).

		Low salt content		Saline
		10 to 30	> 30 to 100	> 100 to 1500
Electrical conductivity at 25 °C	µS/cm			
General requirements		clear, without sediment	clear, without sediment	clear, without sediment
pH value at 25 °C		9 - 10	9 - 10.5	9 - 10.5
According to the German Drinking Water Ordinance/German Drinking Water Treatment Ordinance		≤ 9.5	≤ 9.5	≤ 9.5
Oxygen (O ₂)	mg/l	< 0.1	< 0.05	< 0.02
Values for constant operation may be significantly lower. If suitable non-organic corrosion inhibitors are used, the oxygen concentration in the circulating water can be up to 0.1 mg/l.				
Alkaline earths (Ca + Mg)	mmol/l	< 0.02	< 0.02	< 0.02
Phosphate (PO ₄)	mg/l	< 5	< 10	< 15
According to the German Drinking Water Ordinance/German Drinking Water Treatment Ordinance	mg/l	≤ 7	≤ 7	≤ 7
For Viessmann hot water boilers	mg/l	< 2.5	< 5	< 15
When using oxygen binders:				
Sodium sulphite (Na ₂ SO ₃)	mg/l	–	–	< 10
When using suitable products, observe the guidelines issued by the respective supplier.				

Using antifreeze in boilers

Viessmann boilers are designed and built for water as a heat transfer medium. To protect boiler systems from frost, it may be necessary to treat the boiler or circuit water with antifreeze.

When doing so, observe the following:

- The properties of antifreeze and water are very different.
- The boiling point of pure antifreeze based on glycol is approx. 170 °C.
- The temperature stability of the antifreeze must be sufficient for the particular application.
- Check the compatibility with sealing materials. If other sealing materials are used, take this into account when designing the system.
- Antifreeze developed especially for heating systems contains inhibitors and buffer substances for corrosion protection as well as glycol. When using antifreeze, always observe the manufacturer's instructions regarding minimum and maximum concentrations.
- In a water/antifreeze mixture, the specific heat capacity of the heat transfer medium changes. Take this factor into account when selecting the boilers and system components, such as heat exchanger and pumps. Contact the antifreeze manufacturer to find out the relevant values for the specific heat capacity. For an example calculation of the output change, see below.

- If the system is filled with antifreeze, it must be marked accordingly.
- The quality of the boiler and feedwater must meet the requirements of VDI guideline 2035.
- The systems must be designed as sealed unvented systems, as the antifreeze inhibitors decrease rapidly if airborne oxygen is allowed to enter.
- Diaphragm pressure compensation vessels must comply with DIN 4807.
- Only use oxygen diffusion-resistant hoses or metal hoses for flexible connections.
- Never install zinc plated heat exchangers, tanks or pipes on the primary side of a system, as zinc can be stripped by glycol/water mixtures.

Due to the different physical characteristics of glycol and water, the boiler may suffer a loss of output. Below we have given an example for calculating the output change for operation with antifreeze.

Target	Maximum boiler output when using antifreeze	$Q_{K \text{ glycol}}$
Given	Boiler output Antifreeze Spec. heat capacity Mixing ratio Tyfocor/water	$Q_K = 2 \text{ MW}$ Tyfocor 3.78 kJ/kgK at 80°C 40/60

Calculation:

$$\dot{m} = \frac{\dot{Q}}{c \cdot \Delta t} = \frac{2000 \text{ kW kg K} \cdot 3600 \text{ s}}{4.187 \text{ kWs} \cdot 20 \text{ K} \cdot 1 \text{ h}} = 86000 \frac{\text{kg}}{\text{h}} \hat{=} 86 \text{ t/h}$$

This results in the following:

Design information (cont.)

$$\dot{V} \approx 86 \text{ m}^3/\text{h}$$

$$\dot{Q}_{K \text{ glycol}} = \dot{m} \cdot c \cdot \Delta t = \frac{86000 \text{ kg}}{\text{h}} \cdot 3.78 \frac{\text{kJ}}{\text{h}} \cdot 20\text{K} \cdot \frac{1\text{h}}{3600\text{s}}$$

$$\dot{Q}_{K \text{ glycol}} = 1.8 \text{ MW}$$

Result:

When using 40 % of the antifreeze named above in the heating network, the boiler output is reduced by 10 %. The specific heat capacity is subject to the mixing ratio and temperature, therefore each system must be designed individually.

Prevention of damage through corrosion on the water side

The corrosion resistance of ferrous materials on the heating water side of heating systems and boilers depends on the absence of oxygen in the heating water.

The oxygen, which enters the water in the heating system when it is filled for the first time or topped up, reacts with system materials without causing any damage.

The characteristic blackening of the water after some time in use indicates that free oxygen is no longer present.

The technical rules and in particular VDI Directive 2035-2 therefore recommend that heating systems are designed and operated so that a constant ingress of oxygen into the heating water is prevented.

Opportunities for oxygen ingress during operation:

- Through open expansion vessels receiving a flow
- Through negative pressure in the system
- Through permeable components

Sealed unvented systems – e.g. those equipped with a diaphragm expansion vessel – offer good protection against the ingress of airborne oxygen into the system, if correctly sized and operating at the correct pressure.

At all points in the heating system, including on the intake side of the pump, the pressure must be higher than the pressure of the surrounding atmosphere in all operating states.

The pre-charge pressure of the diaphragm expansion vessel should be checked at least during the annual service.

The use of permeable components, e.g. permeable plastic pipes in underfloor heating systems, should be avoided. Provide system separation if such components are nevertheless used. This must separate the water flowing through the plastic pipes from other heating circuits, e.g. from the boiler, by the provision of a corrosion-resistant heat exchanger.

No further anti-corrosion measures are required for sealed unvented hot water heating systems subject to the above points being observed.

However, take additional precautions where there is a risk of oxygen ingress, for example by adding oxygen binder sodium sulphite (5 - 10 mg/l into the excess). The pH value of the heating water should be between 9.0 and 10.5.

Different conditions apply to systems that contain aluminium components.

Where chemicals are used as part of the corrosion protection, we recommend that the manufacturer of the chemicals issues a certificate of suitability of the additives with regard to the boiler materials and the materials of the other heating system components.

We recommend you refer questions of water treatment to Viessmann Industrieservice or an appropriate specialist.

Further details can be found in VDI Directive 2035-2 and EN 14868.

10.10 Flue gas/water heat exchangers

Installing a flue gas/water heat exchanger downstream for higher efficiency

Installing a flue gas/water heat exchanger downstream of a boiler will result in a significant increase in efficiency. By condensing the flue gases inside the heat exchanger, the boiler turns into a condensing boiler, as required by the Efficiency Directive 92/42/EEC.

- In the case of gas boilers, efficiency is increased by up to 11 %.
- When using fuel oil EL, efficiency is raised by up to 6 % due to the lower water content and, compared to gas, the lower dew point.

The flue gas/water heat exchangers are designed so that they can be retrofitted into existing systems.

The boiler and heat exchanger efficiencies can be increased by downstream connection of the flue gas/water heat exchangers Vitotrans 100/200-LW (up to 2.5 % with the Vitotrans 100-LW and up to 4 % with the Vitotrans 200-LW).

Energy savings through the use of flue gas/water heat exchangers

Different flue gas/water heat exchangers are offered for Vitomax boilers. See page 19.

The increase in efficiency and therefore the energy savings compared to systems without flue gas/water heat exchangers are significantly influenced by the return temperature of the return water flowing through the heat exchanger.

The return temperatures are determined through sizing the system and fall in the case of the Vitomax 300-LT, M343 with rising outside temperature. For heating systems with design temperatures of 75/60 °C and 40/30 °C, the return temperature curve in relation to the outside temperature is illustrated in the diagram on page 34.

The increased efficiency achievable through the downstream flue gas/water heat exchanger when operating with gas and at various heating system temperatures, is shown in the following table. The feasible increases in efficiency are based on the modulating development of the return temperature, and are subject to outside temperature. The various increases in efficiency result from the different flue gas temperatures produced by the upstream boiler.

Design information (cont.)

Heating system design temperature	Increase in efficiency through the Vitotrans 300 with a Vitomax 200 and Vitomax 300	Increase in efficiency through the Vitotrans 300 with a Vitomax 100
90/70 °C	6.0 %	7.0 %
75/60 °C	9.0 %	10.0 %
60/50 °C	10.0 %	11.0 %

The overall efficiency for the condensing unit, comprising the gas boiler and the Vitotrans 300 flue gas/water heat exchanger results from adding the boiler efficiency and the increase in efficiency as a result of the heat exchanger, which has been calculated for the respective system temperature.

Example:

Efficiency Vitomax M343 = 96 %

The increase in efficiency from the Vitotrans 300 at 75/60 °C = 9 % leads to an overall efficiency of the condensing unit of 96 % + 9 % = 105 %.

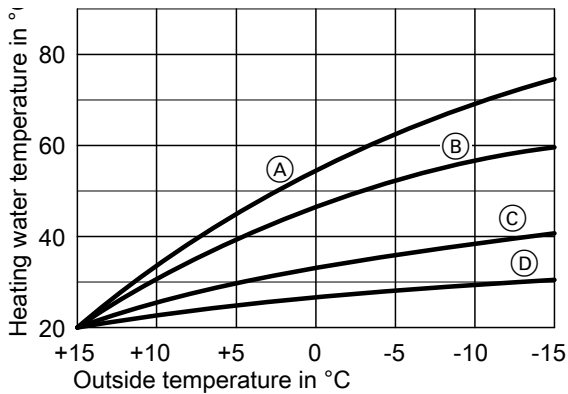

- (A) Flow temperature for heating system 75/60 °C
 (B) Return temperature for heating system 75/60 °C

- (C) Flow temperature for heating system 40/30 °C
 (D) Return temperature for heating system 40/30 °C

Calculation of possible energy savings (B_E)

- Annual heat load Q_a of a boiler system with $\dot{Q}_k = 460$ kW and 1650 full utilisation hours (b_a) per annum:

$$Q_a = b_a \times \dot{Q}_k = 1650 \text{ h/a} \times 460 \text{ kW} \\ = 759000 \text{ kWh/a}$$

- Annual consumption B_N of natural gas LL (net calorific value $H_u = 8.83$ kWh/m³) when using a Vitomax M343 low temperature boiler with a standard seasonal efficiency [to DIN] of $\eta_N = 96$ %:

$$B_N = \frac{Q_a}{\eta_N \cdot H_u} = \frac{759000 \text{ kWh/p.a.}}{0.96 \cdot 8.83 \text{ kWh/m}^3} \\ = 89500 \text{ m}^3/\text{a}$$

- Increase in efficiency η_{AWT} through the downstream installation of a Vitotrans 300 flue gas/water heat exchanger. The design temperature of the heating system routed through the heat exchanger is 75/60 °C.

$$\eta_{AWT} = 9 \text{ % (according to the table on page 34)}$$

$$\eta_{tot} = \eta_N + \eta_{AWT} = 96 \text{ %} + 9 \text{ %} = 105 \text{ %}$$

To calculate the possible energy savings B_E with Vitotrans 100/200-LW, replace the corresponding efficiency and output data of the boiler.

- Annual consumption B_B of natural gas LL (net calorific value $H_u = 8.83$ kWh/m³) when using a Vitomax M343 with a Vitotrans 300 flue gas/water heat exchanger installed downstream:

$$B_B = \frac{Q_a}{\eta_{tot} \cdot H_u} = \frac{759000 \text{ kWh/a}}{1.05 \cdot 8.83 \text{ kWh/m}^3} \\ = 81860 \text{ m}^3/\text{a}$$

- Savings of natural gas LL in m³/a:

$$B_E = B_N - B_B = 89500 \text{ m}^3/\text{a} - 81860 \text{ m}^3/\text{a} \\ = 7640 \text{ m}^3/\text{a}$$

- Savings in percent:

$$\frac{7640 \cdot 100}{89500} = 8.5 \text{ %}$$

Using a downstream Vitotrans 300 flue gas/water heat exchanger can achieve fuel savings of approx. 8.5 %. Substantially higher savings are realised when modernising an out-dated boiler system with low efficiency rates.

5822 427 GB Hydraulic connection

The entire heating water flow rate, relative to the rated boiler heating output and a minimum temperature differential of 20 K can be routed through the Vitotrans 300 flue gas/water heat exchanger.

Design information (cont.)

If only part of the flow is routed via the Vitotrans 300, for example to use a heating circuit with low return temperatures, select the nominal flow rate so that the temperature spread inside the Vitotrans 300, relative to its upper output, is no greater than 10 K.

Condensate and neutralisation (Vitotrans 300)

Gas combustion

Condensate from this type of system should be neutralised. For this, use suitable neutralising systems. In this connection, refer to the relevant authority.

Oil combustion

Condensate from this type of system should be neutralised. For this, use suitable neutralising systems for gas boilers and an active charcoal filter. In this connection, refer to the relevant authority.

Neutralising systems

Matching neutralising systems are available for **condensing units** comprising Viessmann Vitomax boilers and Viessmann **Vitotrans 300** flue gas/water heat exchangers installed downstream of the boiler:

- Granulate neutralising system with optional condensate lifting system and a maximum neutralising performance of 210 l/h for gas boilers
- Liquid neutralising system with lifting pump and a maximum neutralising performance of 420 l/h for gas or oil boilers
- For specifications regarding neutralising systems and accessories, see the datasheet "Boiler accessories"

Positioning the neutralising system

The condensate backs up to the level of the inlet connection to the neutralising system in the boiler, in the flue gas/water heat exchanger or in the flue system, if the entire heating system is installed at the same level.

If the condensate is to drain off completely, set the neutralising system accordingly lower.

Site the neutralising system so that the condensate connection on the boiler or flue gas/water heat exchanger is located higher than the inlet connection of the neutralising system; this enables the condensate to drain completely.

Control units

11.1 Overview of boiler control units and control panels

(See pricelist for allocation to the boilers)

Single boiler systems

Vitotronic 100, type GC1B

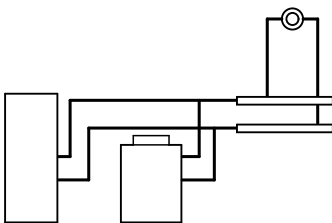

Digital boiler control unit:

- For constant boiler water temperature
- or
- For weather-compensated operation in conjunction with a Vitocontrol control panel and integral Vitotronic 200-H heating circuit control unit
- or
- For weather-compensated operation in conjunction with an external control unit.
- For two-stage or modulating burners.
- With cylinder temperature controller.
- Control of a primary store system with mixer assembly possible (only as an alternative to the control of a constant return temperature raising facility with a regulated 3-way mixing valve).
- With boiler protection function subject to boiler version.
- With integral diagnostic system and additional functions.
- With capability to communicate via LON (LON communication module is an accessory).

According to the Energy Savings Ordinance [Germany], a weather-compensated or room temperature-dependent control unit with time program for reduced mode must be installed downstream.

Control units (cont.)

Vitotronic 200, type GW1B

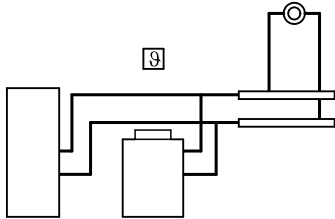

Weather-compensated, digital boiler control unit:

- For single boiler systems.
- For two-stage or modulating burners.
- Programming unit featuring a plain text and graphic display.
- With cylinder temperature controller.
- Control of a primary store system with mixer assembly possible (only as an alternative to the control of a constant return temperature raising facility with a regulated 3-way mixing valve).
- With boiler protection function subject to boiler version.
- With integral diagnostic system and additional functions.
- With capability to communicate via LON (LON communication module is an accessory).

Multi boiler systems

Every boiler in a multi boiler system must be equipped with a Vitotronic 100 (type GC1B). The Vitotronic 300-K (type MW1B) is supplied with one boiler (see pricelist) and should be installed separately.

The LON communication module must be fitted into the Vitotronic 100. See pricelist.

Vitotronic 100, type GC1B

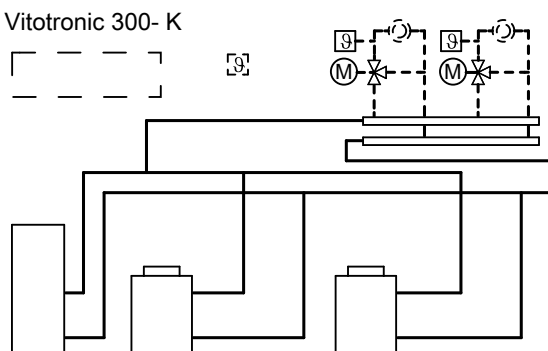

Vitotronic 300-K, type MW1B

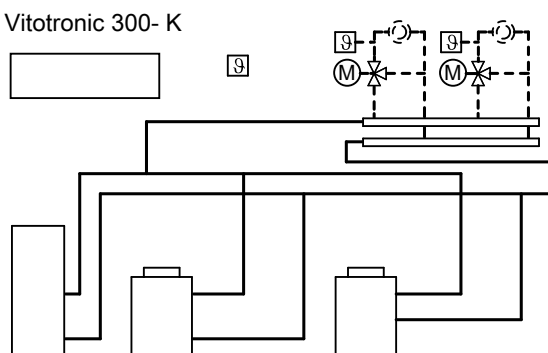

In multi boiler systems with external control unit, the load-dependent burner and boiler control as well as the cylinder temperature control must be implemented by the higher ranking (external) control unit.

Digital boiler control unit:

- For every boiler in a multi boiler system with Viessmann Vitotronic 300-K cascade control unit (supplied with one boiler) or
- For every boiler in a multi boiler system with Vitocontrol control panel and integral weather-compensated Vitotronic 300-K cascade control unit or
- For every boiler in a multi boiler system with external weather-compensated cascade control unit with cylinder thermostat.
- For two-stage or modulating burners.
- With boiler protection function subject to boiler version.
- With integral diagnostic system and additional functions.
- With communication capability via LON (LON communication module is part of the standard delivery).

Weather-compensated, digital cascade and heating circuit control unit:

- For multi boiler systems.
- With boiler sequence strategy.
- For up to two heating circuits with mixers (a further 32 Vitotronic 200-H heating circuit control units can be connected via LON).
An extension kit is required for each heating circuit with mixer.
- In conjunction with Vitotronic 100, type GC1B:
For two-stage or modulating burners.
- With cylinder thermostat or
Control of a primary store system with mixer assembly (only available as an alternative to the control of a constant return temperature raising facility with a regulated 3-way mixing valve)
- With boiler protection functions subject to system version.
- With integral diagnostic system and additional functions.
- With programming unit featuring a plain text and graphic display.
- With capability to communicate via LON (a LON communication module and terminators are part of the standard delivery)

Switching points

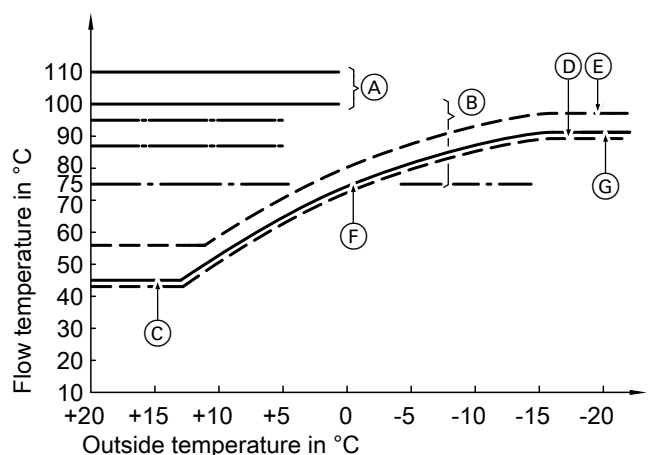

- (A) Setting options for the high limit safety cut-out of the Vitotronic boiler control unit (delivered condition 110 °C)
- (B) Setting options for the temperature controller of the Vitotronic boiler control unit (delivered condition 95 °C)
- (C) Low-end boiler water temperature (see operating conditions page 6)
- (D) Burner starting points
- (E) Burner shutdown points
- (F) Selected heating curve
- (G) Set max. boiler water temperature

11.2 Components in the delivered condition

Allocation to control unit types

Vitotronic	100	200	300-K
Type	GC1B	GW1B	MW1B
Components			
Boiler water temperature sensor	x	x	
Cylinder temperature sensor		x	x
Outside temperature sensor		x	x
Contact temperature sensor (see accessories)			x
LON communication module (see accessories)	x		x
Note for Vitotronic 100, type GC1B only in multi boiler systems			
LON connecting cable (see accessories)	x		x
Terminator (see accessories)			x

Boiler water temperature sensor

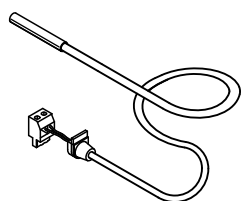

Sensor type: Viessmann NTC 10 kΩ, at 25 °C

Permissible ambient temperature

- During operation: 0 to +130 °C
- During storage and transport: -20 to +70 °C

Specification

Lead length: 3.7 m, fully wired

IP rating: IP 32 to EN 60529; ensure through appropriate design and installation

Control units (cont.)

Cylinder temperature sensor

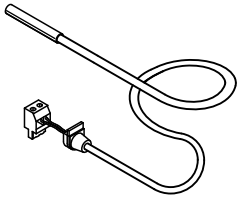

Specification

Lead length	5.8 m, fully wired
IP rating	IP 32 to EN 60529; ensure through design/installation
Sensor type	Viessmann NTC 10 kΩ, at 25 °C
Permissible ambient temperature	
– during operation	0 to +90 °C
– during storage and transport	–20 to +70 °C

Outside temperature sensor

Installation site:

- North or north-western wall of the building
- 2 to 2.5 m above the ground, for multi storey buildings in the upper half of the second floor

Connection:

- 2-core lead, length max. 35 m with a cross-section of 1.5 mm² (copper).
- Never route this lead immediately next to 230/400 V cables

Specification

IP rating	IP 43 to EN 60529 ensure through appropriate design/installation
Sensor type	Viessmann NTC 10 kΩ, at 25 °C
Permissible ambient temperature during operation, storage and transport	–40 to +70 °C

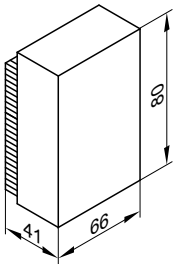

11.3 Vitotronic 100, type GC1B, part no. 7498 901

Specification

Construction

The control unit comprises a standard unit, electronics modules and a programming unit.

Standard unit:

- ON/OFF switch
- Test key
- Emissions test switch
- Optolink laptop interface
- Temperature controller
DIN TR 116707
or
DIN TR 110708
- High limit safety cut-out
DIN STB 116907
or
DIN STB 115408
- Fuses
- Operating and fault indicators
- Plug connection chamber
 - Connection of external equipment via system plug
 - Connection of three-phase consumers via additional contactors

Programming unit

- Easy operation through high contrast display with large fonts.
- User prompts through pictograms
- Operating keys:
 - Navigation
 - Confirmation
 - Settings/menu

Settings:

- Boiler water temperature
- Codes
- Actuator tests
- Test mode

Only in conjunction with single boiler systems:

- DHW temperature
- Operating program

Indications:

- Boiler water temperature
- DHW temperature (only in single boiler systems)
- Operating data
- Diagnostic details
- Maintenance and fault messages

Functions

- Control of the boiler water temperature (= system flow temperature) to the specified value.
- Electronic maximum boiler water temperature limit.
- Pump anti-seizing protection.
- Integral diagnostic system.
- Flue gas temperature monitoring in connection with flue gas temperature sensor.
- Maintenance display.

Control units (cont.)

- External fault message facility can be connected.
- With boiler protection function subject to boiler/system version:
 - Therm-Control start-up system
 - Flow rate reduction for downstream heating circuits
 - Shunt pump control
 - Control of a constant return temperature raising facility with regulated 3-way mixing valve (only as an alternative to the control of a primary store system with mixer assembly)

Single boiler systems:

- Adaptive cylinder temperature controller with priority control (heating circuit pump off).
- Auxiliary function for DHW heating (short term heating to a higher temperature).
- Control of solar DHW heating in conjunction with a solar control module type SM1.
- Control of a primary store system with mixer assembly (only as an alternative to control of a constant return temperature raising facility with regulated 3-way mixing valve).
- Functions via external contacts:
 - External demand with set minimum boiler water temperature
 - External changeover of stepped/modulating burners
- Additional functions via extension EA1 (accessory):
 - External demand through default set boiler water temperature via 0 to 10 V input
 - 3 digital inputs for the following functions:
 - External blocking
 - External blocking with fault message input
 - Fault message input
- Additional functions via extension AM1 (accessory):
 - Control of up to two circulation pumps, if output $\boxed{20}$ is already assigned at the control unit:
 - Circulation pump for flue gas/water heat exchanger
 - Circulation pump for neutralising system

Multi boiler system with Vitotronic 300-K cascade control unit:

- Functions via external contacts:
 - External blocking
 - Start boiler externally as the last one in the boiler sequence
 - External changeover of stepped/modulating burners
- Additional functions via extension AM1 (accessory):
 - Control of up to two circulation pumps, if output $\boxed{20}$ is already assigned at the control unit:
 - Circulation pump for flue gas/water heat exchanger
 - Circulation pump for neutralising system

Multi boiler systems with third party control unit:

- Functions via external contacts:
 - Boiler enable/butterfly valve control
 - External demand burner stage 1
 - External demand burner stage 2
 - External changeover of stepped/modulating burners
- Additional functions via extension EA1 (accessory):
 - External demand through default set boiler water temperature and boiler enable via 0 to 10 V input

Note

An extension EA1 must be connected to **every** Vitotronic 100.

- Additional functions via extension AM1 (accessory):
 - Control of up to two circulation pumps, if output $\boxed{20}$ is already assigned at the control unit:
 - Circulation pump for flue gas/water heat exchanger
 - Circulation pump for neutralising system

Control characteristics

- P-characteristics with two-point output when using a burner with multiple stages
PI characteristics with three-point output for modulating burners, if installed
- Temperature controller for limiting the boiler water temperature: 95 °C, adjustable to 100, 110 °C
- Adjusting the high limit safety cut-out: 110 °C, adjustable to 100 °C
- Maximum boiler water temperature limit: 20 up to 127 °C (lower switching point subject to boiler/boiler coding card)
- Setting range of the set DHW temperature: 10 to 60 °C, adjustable to 10 to 95 °C

Boiler coding card

For matching to the boiler (supplied with the boiler).

Setting operating programs

Frost protection monitoring for the boiler and DHW cylinder is enabled in all operating programs.

The following operating programs can be selected:

- Single boiler systems:
 - Heating and DHW
 - DHW only
 - Standby mode
- Multi boiler systems:
 - Heating
 - Standby mode

Summer mode (only in single boiler systems)

("DHW only")

The burner starts only when the DHW cylinder needs reheating (controlled by the cylinder temperature controller).

The respective lower boiler water temperature of each boiler is maintained if required.

Specification

Rated voltage	230 V~
Rated frequency	50 Hz
Rated current	2 x 6 A~
Power consumption	10 W
Safety category	I
IP rating	IP 20 D to EN 60529
Function	Ensure through design/installation Type 1B to EN 60 730-1
Permissible ambient temperature	0 to +40 °C
– During operation	Installation in living spaces and boiler rooms (standard ambient conditions)
– During storage and transport	-20 to +65 °C



Control units (cont.)

Rated relay output breaking capacity

[20]	Primary pump, primary store system (only in single boiler systems) or Circulation pump, flue gas/water heat exchanger or Switching output	4(2) A, 230 V~
[21]	Circulation pump for cylinder heating	4(2) A, 230 V~
[29]	Shunt pump/boiler circuit pump	4(2) A, 230 V~
[50]	Central fault message	4(2) A, 230 V~

[52]	Butterfly valve or Motor, 3-way mixing valve, constant return temperature raising or Motor, 3-way mixing valve, primary store system	0.2 (0.1) A, 230 V~ Max. 6 A, 230 V~
Total		
[41]	Burner	4(2) A, 230 V~
[90]	Burner, 2-stage	1 (0.5) A, 230 V~
[90]	Burner, modulating	0.2 (0.1) A, 230 V~

Delivered condition

- Control with integral programming unit
- Boiler water temperature sensor
- 1 bag with technical documentation
- Only in conjunction with multi boiler systems:
LON communication module and a connecting cable (7 m long) for data exchange between control units

Heating system with DHW cylinder

Only in connection with single boiler systems; order separately:

- Cylinder temperature sensor and circulation pump with check valve for regulating the cylinder temperature
or
- Vitotrans 222 primary store system with mixer assembly and cylinder temperature sensor

Communication

The LON communication module (accessory) is required for communication with other control units, e.g. with the Vitotronic 200-H.

11.4 Vitotronic 200, type GW1B, part no. 7498 902

Specification

Construction

The control unit comprises a standard unit, electronics modules and a programming unit.

Standard unit:

- ON/OFF switch
- Test key
- Emissions test switch
- Optolink laptop interface
- Temperature controller
DIN TR 116707
or
DIN TR 110708
- High limit safety cut-out
DIN STB 116907
or
DIN STB 115408
- Fuses
- Operating and fault indicators
- Plug connection chamber
 - Connection of external equipment via a system plug
 - Connection of three-phase consumers via additional contactors

Programming unit

- Simple operation:
 - Plain text display with graphic ability
 - Large font and black/white depiction for good contrast
 - Context-sensitive help
- Operating keys:
 - Navigation
 - Confirmation
 - Help and additional information
 - Menu

- Settings:
 - Set room temperatures
 - DHW temperature
 - Operating program
 - Time programs for central heating, DHW heating and DHW circulation pump
 - Economy mode
 - Party mode
 - Holiday program
 - Heating curves
 - Codes
 - Actuator tests
- Displays:
 - Boiler water temperature
 - DHW temperature
 - Operating data
 - Diagnostic details
 - Maintenance and fault messages
- Available languages:
 - German
 - Bulgarian
 - Czech
 - Danish
 - English
 - Spanish
 - Estonian
 - French
 - Croatian
 - Italian
 - Latvian
 - Lithuanian
 - Hungarian
 - Dutch
 - Polish
 - Russian
 - Romanian
 - Slovenian
 - Finnish
 - Swedish
 - Turkish

Functions

- Weather-compensated control of the boiler water temperature (= system flow temperature).
- Electronic maximum and minimum flow temperature limit.
- Demand-dependent heating circuit pump and burner shutdown (not for burners in boilers with a lower boiler water temperature limit).
- Adjustment of a variable heating limit.
- Pump anti-seizing protection.
- Integral diagnostic system.
- Flue gas temperature monitoring in connection with flue gas temperature sensor.
- Maintenance display.
- Adaptive cylinder temperature controller with priority control (heating circuit pump off).
- Additional function for DHW heating (brief heating to a higher temperature).
- Control of solar DHW heating in conjunction with the solar control module, type SM1.
- Control of a primary store system with mixer assembly (only as an alternative to the control of a constant return temperature raising facility with a regulated 3-way mixing valve).
- External fault message facility can be connected.
- With boiler protection functions subject to boiler version:
 - Therm-Control start-up system
 - Flow rate reduction for downstream heating circuits
 - Shunt pump control
 - Control of a constant return temperature raising facility with a regulated 3-way mixing valve (only as an alternative to the control of a primary store system with mixer assembly)
- Functions via external contacts:
 - External operating program changeover
 - External blocking
 - External demand with set minimum boiler water temperature
 - External changeover of multi stage/modulating burners
- Additional functions via extension EA1 (accessory):
 - External demand through default set boiler water temperature via 0 to 10 V input
 - Switching a feed pump to a substation or Signalling reduced mode (reduction of the heating circuit pump speed) via a potential-free output
 - 3 digital inputs for the following functions:
 - External blocking with fault message input
 - Fault message input
 - Brief operation of the DHW circulation pump
- Additional functions via extension AM1 (accessory):
 - Control of up to two circulation pumps, if output 20 is already assigned at the control unit:
 - Circulation pump for flue gas/water heat exchanger
 - Circulation pump for neutralising system
 - Heating circuit pump

The requirements of EN 12831 for calculating the heat load are met. To reduce the heat-up load, the reduced room temperature will be raised in the case of low outside temperatures. The flow temperature will be raised for a limited time to reduce the heat-up time after a set-back phase.

According to the Energy Saving Ordinance [Germany], the temperature in each room must be individually controlled, e.g. through thermostatic valves.

Control characteristics

- P characteristics with two-point output when using a multi stage burner
 - PI characteristics with three-point output when using a modulating burner
- Temperature controller for limiting the boiler water temperature: 95 °C, adjustable to 100, 110 °C
- High limit safety cut-out setting: 110 °C, adjustable to 100 °C

- Heating curve setting range:
 - Slope: 0.2 to 3.5
 - Level: -13 to 40 K
 - Maximum limit of the flow temperature: 10 to 127 °C
 - Minimum limit of the flow temperature: 1 to 127 °C
- Setting range of the set DHW temperature: 10 to 60 °C, adjustable to 10 to 95 °C

Boiler coding card

For matching to the boiler (supplied with the boiler).

Time switch

Digital time switch (integrated into the programming unit)

- Individual day and seven-day program, annual calendar
 - Automatic summer/wintertime changeover
 - Automatic function for DHW heating and DHW circulation pump
 - Time, day and standard switching times for central heating, DHW heating and the DHW circulation pump are factory-set
 - Switching times are individually programmable; up to four time phases per day
- Shortest switching interval: 10 min
Power reserve: 14 days

Setting operating programs

The heating system frost protection (see frost protection function) applies to all operating programs.

The following operating programs can be selected:

- Heating and DHW
 - DHW only
 - Standby mode
- Optional external operating program changeover.

Frost protection

- The frost protection function is switched on if the outside temperature drops below approx. +1 °C, i.e. the heating circuit pump is switched on and the boiler water is maintained at a lower temperature (see chapter "Operating conditions with Vitotronic boiler control units").
- "Standby mode":
 - The frost protection function is switched off if the outside temperature rises above approx. +3 °C, i.e. the heating circuit pump and burner are switched off.
- "Heating and DHW"
 - The frost protection function is switched off if the outside temperature rises above approx. +3 °C. This means the heating circuit pump is switched off and the lower boiler water temperature for the relevant boiler is maintained if required (see chapter "Operating conditions with Vitotronic boiler control units").

Summer mode

("DHW only")

The burner starts only when the DHW cylinder needs reheating (controlled by the cylinder temperature controller).

The lower boiler water temperature of each boiler is maintained if necessary.

Heating curve setting (slope and level)

The Vitotronic controls the boiler water temperature (= system flow temperature) in weather-compensated mode.

The flow temperature required to reach a specific room temperature depends on the heating system and the thermal insulation of the building to be heated.

Adjusting the heating curve matches the boiler water temperature to these conditions.

The upper boiler water temperature is limited by the temperature controller and the electronic maximum limiter.

Control units (cont.)

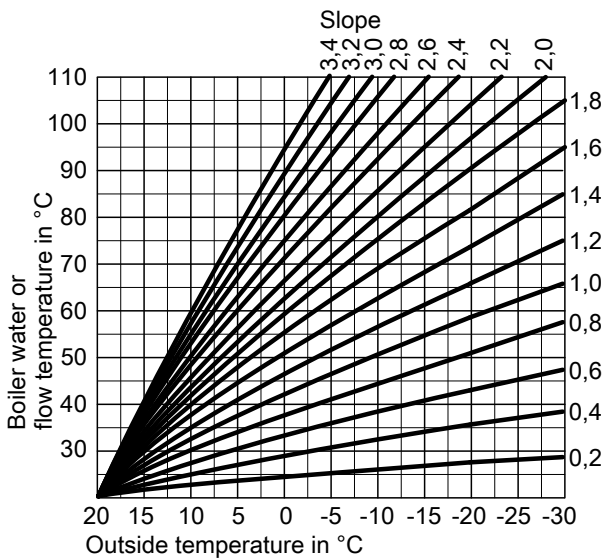

Specification

Rated voltage	230 V~
Rated frequency	50 Hz
Rated current	2 x 6 A~
Power consumption	10 W
Safety category	I
IP rating	IP 20 D to EN 60529 Ensure through appropriate design/installation
Function	Type 1B to EN 60 730-1

Permissible ambient temperature

- During operation	0 to +40 °C Installation in living spaces and boiler rooms (standard ambient conditions)
- During storage and transport	-20 to +65 °C

Rated relay output breaking capacity

[20]	Heating circuit pump or Primary pump, primary store system or Circulation pump – flue gas/water heat exchanger or Switching output	4(2) A, 230 V~
[21]	Circulation pump for cylinder heating	4(2) A, 230 V~
[28]	DHW circulation pump	4(2) A, 230 V~
[29]	Shunt pump/boiler circuit pump	4(2) A, 230 V~
[50]	Central fault message	4(2) A, 230 V~
[52]	Motor, 3-way mixing valve, constant return temperature raising or Motor, 3-way mixing valve, primary store system	0.2 (0.1) A, 230 V~ Max. 6 A, 230 V~
Total		
[41]	Burner	4(2) A, 230 V~
[90]	Burner, 2-stage	1 (0.5) A, 230 V~
[90]	Burner, modulating	0.2 (0.1) A, 230 V~

Delivered condition

- Control unit with integral programming unit
- Outside temperature sensor
- Boiler water temperature sensor
- Cylinder temperature sensor
- Bag with technical documentation

Heating system with DHW cylinder

Order separately:

- Circulation pump with check valve for regulating the cylinder temperature
or
- Vitotrans 222 primary store system with mixer assembly

Communication

The LON communication module (accessories) is required for communication with other control units.

11.5 Vitotronic 300-K, type MW1B, part no. 7498 906

Specification

Construction

The control unit comprises a standard unit, electronic modules and a programming unit.

Standard unit:

- ON/OFF switch
- Emissions test switch
- Optolink laptop interface
- Fuse
- Operating and fault indicators
- Plug connection chamber
 - Connection of external equipment via system plug
 - Connection of three-phase consumers via additional contactors

Programming unit

- Simple operation:
 - Plain text display with graphic ability
 - Large font and black/white depiction for good contrast
 - Context-sensitive help
- Operating keys:
 - Navigation
 - Confirmation
 - Help and additional information
 - Extended menu

- Settings:
 - Boiler sequence
 - Set room temperatures
 - DHW temperature
 - Operating program
 - Time programs for central heating, DHW heating and DHW circulation pump
 - Economy mode
 - Party mode
 - Holiday program
 - Heating curves
 - Codes
 - Actuator tests
- Indications:
 - Common flow temperature
 - DHW temperature
 - Operating data
 - Diagnostic details
 - Fault messages
- Available languages:
 - German
 - Bulgarian
 - Czech
 - Danish
 - English
 - Spanish
 - Estonian
 - French
 - Croatian
 - Italian
 - Latvian
 - Lithuanian
 - Hungarian
 - Dutch
 - Polish
 - Russian
 - Romanian
 - Slovenian
 - Finnish
 - Swedish
 - Turkish

Functions

- Weather-compensated cascade control of the system flow temperature in a multi boiler system with up to four boilers with Vitotronic 100, type GC1B (modulating), and the flow temperature of two heating circuits with mixer.
- The boilers are controlled by the Vitotronic 100, type GC1B, according to a freely selectable boiler sequence strategy.
- Electronic maximum and minimum limitation of the flow temperature in heating circuits with mixer.
- Demand-dependent heating circuit pump shutdown.
- Adjustment of a variable heating limit.
- Pump anti-seizing protection.
- Integral diagnostic system.
- Adaptive cylinder temperature controller with priority control (heating circuit pump off, mixer close).
- Auxiliary function for DHW heating (short term heating to a higher temperature).
- Control of solar DHW heating in conjunction with the solar control module, type SM1.
- Control of a primary store system with mixer assembly (only as an alternative to control of a constant return temperature raising facility with regulated 3-way mixing valve).
- External fault message facility can be connected.
- Screed drying program for the heating circuits with mixer.

- With boiler protection functions subject to system version:
 - Distribution pump control
or
 - Shunt pump control
or
 - Control of a constant return temperature raising facility with regulated 3-way mixing valve (only as an alternative to the control of a primary store system with mixer assembly)
- Functions via external contacts:
 - External changeover of operating program/external mixer open
 - External blocking/external mixer close
 - External demand with minimum set flow temperature
- Additional functions via extension EA1 (accessory):
 - External demand by setting a default flow temperature via 0 to 10 V input
or
 - Switching a feed pump to a substation
or
 - Signalling reduced mode (reduction of the heating circuit pump speed) via a potential-free output
 - 3 digital inputs for the following functions:
 - External operating program changeover, separate for heating circuits 1 to 3
 - External blocking with fault message input
 - Fault message input
 - Brief operation of the DHW circulation pump

The requirements of EN 12831 for calculating the heat load are met. To reduce the heat-up load, the reduced room temperature will be raised in the case of low outside temperatures. The flow temperature will be raised for a limited time to reduce the heat-up time after a set-back phase.

According to the Energy Saving Ordinance [Germany], the temperature in each room must be individually controlled, e.g. through thermostatic valves.

Control characteristics

- P characteristics with three-point output
- Setting range for heating curves:
 - Slope: 0.2 to 3.5
 - Level: -13 to 40 K
 - Maximum limit of the flow temperature: 10 to 127 °C
 - Minimum limit of the flow temperature: 1 to 127 °C
- Differential temperature for a heating circuit with mixer: 0 to 40 K
- Setting range of the set DHW temperature: 10 to 60 °C, adjustable to 10 to 95 °C

Time switch

- Digital time switch (integrated into the programming unit)
- Individual day and seven-day program, annual calendar
 - Automatic summer/wintertime changeover
 - Automatic function for DHW heating and DHW circulation pump
 - Time, day and standard switching times for central heating, DHW heating and the DHW circulation pump are factory-set
 - Switching times are individually programmable, i.e. up to four time phases per day
- Shortest switching interval: 10 min
Power reserve: 14 days

Setting operating programs

Frost protection monitoring (see frost protection function) for the heating system is enabled in all operating programs.

The following operating programs can be selected:

- Heating and DHW
- DHW only
- Standby mode

External operating program changeover possible, for all heating circuits together or separately.

Control units (cont.)

Frost protection

- The frost protection function will be switched on if the outside temperature drops below approx. +1 °C, i.e. the heating circuit pumps will be started and the flow temperature will be maintained at a minimum temperature of 10 °C.
- The frost protection function will be switched off when the outside temperature exceeds approx. +3 °C, i.e. the heating circuit pumps will be stopped.

Summer mode

("DHW only")

The burners start only when the DHW cylinder needs reheating (controlled by the cylinder temperature controller).

The respective lower boiler water temperature of each boiler is maintained if required.

Heating curve setting (slope and level)

The Vitotronic regulates the system flow temperature and the flow temperature of the heating circuits with mixer in weather-compensated mode. For this, the system flow temperature is automatically regulated to between 0 and 40 K (delivered condition 8 K) above the highest currently required set flow temperature of the heating circuits with mixer.

The flow temperature required to reach a specific room temperature depends on the heating system and the thermal insulation of the building to be heated.

Adjusting the heating curves matches the system flow temperature and the flow temperature of the heating circuits with mixer to these operating conditions.

The upper flow temperature of the heating circuits with mixer is limited by the temperature controller and the electronic maximum boiler water temperature limiter of the Vitotronic 100, type GC1B.

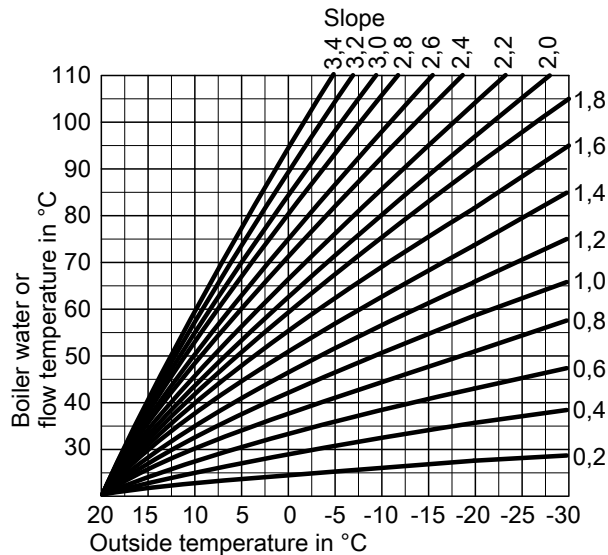

Specification

Rated voltage	230 V~	
Rated frequency	50 Hz	
Rated current	6 A~	
Power consumption	10 W	
Safety category	I	
IP rating	IP 20 D to EN 60529	
	Ensure through design/installation	
Function	Type 1B to EN 60 730-1	
Permissible ambient temperature	0 to +40 °C	
– During operation	Installation in living spaces and boiler rooms (standard ambient conditions)	
– During storage and transport	–20 to +65 °C	
Rated relay output breaking capacity		
20	Heating circuit pump	
	or	
	Primary pump, primary store system	4(2) A, 230 V~
21	Circulation pump for cylinder heating	4(2) A, 230 V~
	or	
28	DHW circulation pump	4(2) A, 230 V~
29	Shunt pump/distribution pump	4(2) A, 230 V~
50	Central fault message	4(2) A, 230 V~
52	Mixer motor, extension kit, mixer	
	or	
	Motor, 3-way mixing valve, constant return temperature raising	
	or	
	Motor, 3-way mixing valve, primary store system	0.2 (0.1) A, 230 V~
Total		Max. 6 A, 230 V~

Dimensions

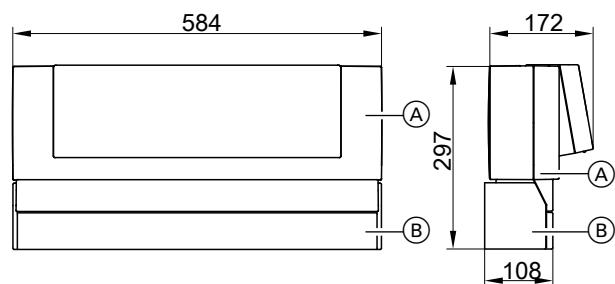

- (A) Vitotronic 300-K
- (B) Mounting bracket

Delivered condition

- Control with integral programming unit
- LON communication module with 2 terminators
- Outside temperature sensor
- Flow temperature sensor
- Cylinder temperature sensor
- Mounting bracket
- Bag with technical documentation

The control unit is delivered with one of the boilers of the multi boiler system (see pricelist) and is fitted with the mounting bracket either to the wall or the side of the boiler.

Heating system with DHW cylinder

Order separately:

- Circulation pump with check valve for regulating the cylinder temperature
- or
- Vitotrans 222 primary store system with mixer assembly

Heating system with heating circuit with mixer

A mixer extension kit (accessory) is required for each heating circuit with mixer.

11.6 Control unit accessories

Allocation of accessories according to oil/gas boiler control unit type

Vitotronic Type	Single boiler system		Multi boiler system	
	100 GC1B	200 GW1B	100 GC1B	300-K MW1B
Accessories				
Vitotrol 200A		X		X
Vitotrol 300A		X		X
Vitotrol 200 RF		X		X
Vitotrol 300 RF		X		X
Wireless base station		X		X
Wireless outside temperature sensor		X		X
Wireless repeater		X		X
Room temperature sensor				X
Contact temperature sensor	X	X	X	X
Immersion temperature sensor	X	X	X	X
Sensor well 100 mm	X	X	X	X
Sensor well 150 mm	X	X	X	X
Sensor well 200 mm	X	X	X	X
Flue gas temperature sensor	X	X	X	
Cylinder temperature sensor	X			
Extension kit for one heating circuit with mixer				X
Mixer motor				X
Plug ^[20]	X	X	X	X
Plug ^[52]	X	X	X	X
Plugs for sensors	X	X	X	X
Immersion thermostat				X
Contact thermostat				X
Radio clock receiver		X		X
Plug-in adaptor for external safety equipment	X	X	X	
Contact relay	X	X	X	X
Mating plugs ^[41] and ^[90]	X	X	X	
Mounting kit for installation in control panel	X	X	X	X
Solar control module, type SM1	X	X		X
Extension AM1	X	X	X	
Extension EA1	X	X		
Vitocom 100, type LAN1		X		X ^{*16}
Vitocom 100, type GSM	X	X		
Vitocom 200, type GP1	X	X		
Vitocom 300	X	X		X
LON connecting cable	X	X		X
LON coupling	X	X	X	X
LON plug-in connector	X	X	X	X
LON socket	X	X	X	X
Terminator	X	X		
LON communication module	X	X		
Vitogate 200	X	X		

Information regarding Vitotrol 200A and 300A

One Vitotrol 200A or one Vitotrol 300A can be used for every heating circuit in a heating system.

The Vitotrol 200A can regulate one heating circuit; the Vitotrol 300A up to three heating circuits.

Up to three remote controls can be connected to the control unit.

Note

Hardwired remote control units cannot be combined with the wireless base station.

Vitotrol 200A

Part no. Z008 341
KM BUS subscriber

- Indications:
 - Room temperature
 - Outside temperature
 - Operating condition
- Settings:
 - Set room temperature for standard mode (day temperature)

^{*16} In conjunction with Vitodata 100



Control units (cont.)

Note

The set room temperature for reduced mode (night temperature) is set at the control unit.

- Operating program
- Party and economy mode can be enabled via keys
- Integral room temperature sensor for room temperature hook-up (only for one heating circuit with mixer)

Installation site:

- Weather-compensated mode:
Installation anywhere in the building.
- Room temperature hook-up:
The integral room temperature sensor captures the actual room temperature and corrects the flow temperature if necessary.

The captured room temperature is dependent on the installation site:

- Main living room on an internal wall opposite radiators.
- Not on shelves or in recesses.
- Never install immediately by a door or heat source (e.g. direct sunlight, fireplace, TV set, etc.).

Connection:

- Two-core cable, length max. 50 m (even if connecting several remote control units).
- Never route this cable immediately next to 230/400 V cables.
- LV plug as standard delivery.

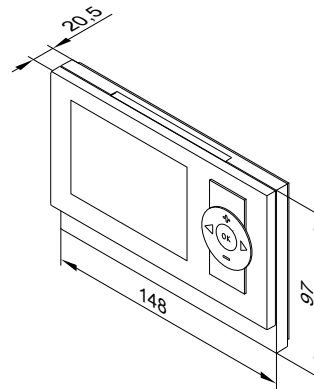

Specification

Power supply via KM BUS	
Power consumption	0.2 W
Safety category	III
IP rating	IP 30 to EN 60529
	Ensure through design/installation
Permissible ambient temperature	
– during operation	0 to +40 °C
– during storage and transportation	-20 to +65 °C
Setting range of the set room temperature for standard mode	3 to 37 °C

Vitotrol 300A

Part no. Z008 342

KM BUS subscriber

- Indications:
 - Room temperature
 - Outside temperature
 - Operating program
 - Operating condition
 - Solar yield as graphic display
- Settings:
 - Set room temperature for standard mode (day temperature) and reduced mode (night temperature)
 - Set DHW temperature
 - Operating program, switching times for heating circuits, DHW heating and DHW circulation pump plus further settings via plain text menu on the display
- Party and economy mode can be enabled via the menu
- Integral room temperature sensor for room temperature hook-up (only for one heating circuit with mixer)

Installation site:

- Weather-compensated mode:
Installation anywhere in the building.
- Room temperature hook-up:
The integral room temperature sensor captures the actual room temperature and corrects the flow temperature if necessary.

The captured room temperature is dependent on the installation site:

- Main living room on an internal wall opposite radiators.
- Not on shelves or in recesses.
- Never install immediately by a door or heat source (e.g. direct sunlight, fireplace, TV set, etc.).

Connection:

- Two-core cable, length max. 50 m (even if connecting several remote control units).
- Never route this cable immediately next to 230/400 V cables.
- LV plug as standard delivery.

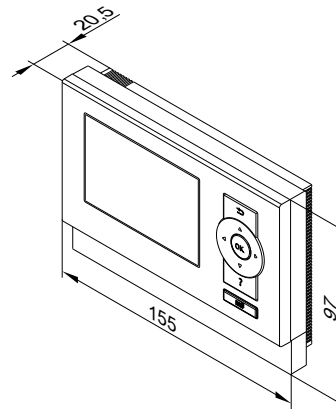

Specification

Power supply via KM BUS	
Power consumption	0.5 W
Safety category	III
IP rating	IP 30 to EN 60529
	Ensure through design/installation
Permissible ambient temperature	
– during operation	0 to +40 °C
– during storage and transportation	-20 to +65 °C
Setting range of the set room temperature	3 to 37 °C

Control units (cont.)

Information regarding the Vitotrol 200 RF and Vitotrol 300 RF

Wireless remote controls with integral wireless transmitter for operation with the wireless base station.

One Vitotrol 200 RF or one Vitotrol 300 RF can be used for every heating circuit in a heating system.

The Vitotrol 200 RF can regulate one heating circuit; the Vitotrol 300 RF up to three heating circuits.

Up to three wireless remote controls can be connected to the control unit.

Note

The wireless remote controls **cannot** be combined with wired remote controls.

Vitotrol 200 RF

Part no. Z011 219

Wireless subscriber

■ Indications:

- Room temperature
- Outside temperature
- Operating condition

■ Settings:

- Set room temperature for standard mode (day temperature)

Note

The set room temperature for reduced mode (night temperature) is set at the control unit.

- Operating program

■ Party and economy mode can be enabled via keys

■ Integral room temperature sensor for room temperature hook-up (only for one heating circuit with mixer)

Installation site:

■ Weather-compensated mode:

Installation anywhere in the building.

■ Room temperature hook-up:

The integral room temperature sensor captures the actual room temperature and corrects the flow temperature if necessary.

The captured room temperature is dependent on the installation site:

- Main living room on an internal wall opposite radiators.
- Not on shelves or in recesses.
- Never install immediately by a door or heat source (e.g. direct sunlight, fireplace, TV set, etc.).

Note

Refer to "Wireless accessories" technical guide.

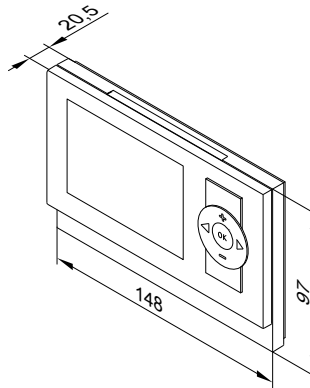

Specification

Power supply via 2 AA batteries 3 V

Wireless frequency

868.3 MHz

Wireless protocol

EnOcean

Wireless range

See "Wireless accessories" technical guide

Safety category

III

IP rating

IP 30 to EN 60529

Ensure through design/installation

Permissible ambient temperature

– during operation

0 to +40 °C

– during storage and transportation

–20 to +65 °C

Setting range of the set room temperature for standard mode

3 to 37 °C

Vitotrol 300 RF with table-top dock

Part no. Z011 410

Wireless subscriber

■ Indications:

- Room temperature
- Outside temperature
- Operating condition
- Solar yield as graphic display

■ Settings:

- Set room temperatures for standard mode (day temperature) and reduced mode (night temperature)
 - Set DHW temperature
 - Heating program, switching times for heating circuits, DHW heating and DHW circulation pump plus further settings via plain text menu on the display
 - Party and economy mode can be enabled via keys
- #### ■ Integral room temperature sensor

■ Plug-in power supply unit

■ Two NiMH batteries for operating outside the table-top dock

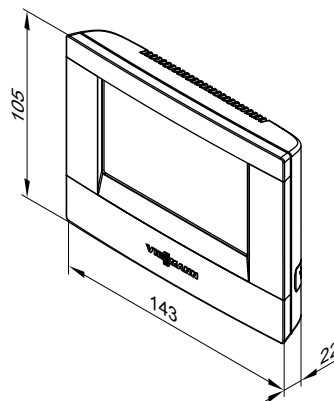

Vitotrol 300 RF

Standard delivery:

- Vitotrol 300 RF
- Table-top dock

Control units (cont.)

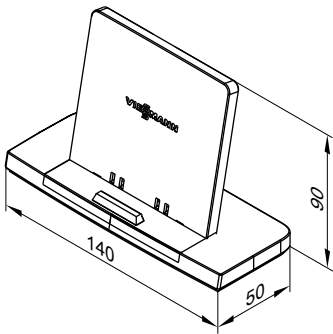

Table-top dock

Specification

Power supply via plug-in power supply unit 230 V~/5 V-

Power consumption
Radio frequency
Wireless protocol
Wireless range

2.4 W
868.3 MHz
EnOcean
See "Wireless accessories" technical guide
II
IP 30 to EN 60529
Ensure through assembly/installation

Safety category
IP rating

Permissible ambient temperature

- During operation 0 to +40 °C
- During storage and transport -25 to +60 °C
Range of the set room temperature 3 to 37 °C

Vitotrol 300 RF with wall mounting bracket

Part no. Z011 412

Wireless subscriber

■ Indications:

- Room temperature
- Outside temperature
- Operating condition
- Solar yield as graphic display

■ Settings:

- Set room temperatures for standard mode (day temperature) and reduced mode (night temperature)
- Set DHW temperature
- Heating program, switching times for heating circuits, DHW heating and DHW circulation pump plus further settings via plain text menu on the display
- Party and economy mode can be enabled via the menu

- Integral room temperature sensor for room temperature hook-up (only for one heating circuit with mixer)

Installation location:

- Weather-compensated mode:
Installation anywhere in the building.

■ Room temperature hook-up:

The integral room temperature sensor captures the actual room temperature and affects any necessary correction of the flow temperature.

The captured room temperature is dependent on the installation location:

- Main living room on an internal wall opposite radiators.
- Not on shelves, in recesses.
- Never immediately by a door or heat source (e.g. direct sunlight, fireplace, TV set, etc.).

Note

Observe the "Wireless accessories" technical guide.

Standard delivery:

- Vitotrol 300 RF
- Wall mounting bracket
- Power supply unit for installation into a plaster box
- Two NiMH batteries for operating outside the wall mounting bracket

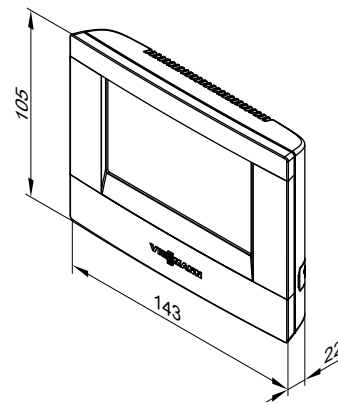

Vitotrol 300 RF

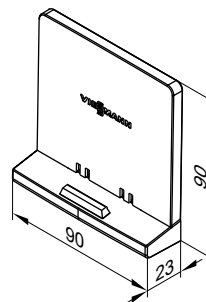

Wall mounting bracket

Control units (cont.)

Specification

Power supply via power supply unit
230 V~/4 V
for installation into a plaster box
Power consumption
Radio frequency
Wireless protocol

2.4 W
868.3 MHz
EnOcean

Wireless range

Safety category
IP rating

Permissible ambient temperature
– During operation
– During storage and transport
Range of the room temperature

See "Wireless accessories" technical guide
II
IP 30 to EN 60529
Ensure through assembly/installation

0 to +40 °C
–25 to +60 °C
3 to 37 °C

Wireless base station

Part no. Z011 413

KM BUS subscriber

For communication between the Vitotronic control unit and the following wireless components:

- Wireless Vitotrol 200 RF remote control
- Wireless Vitotrol 300 RF remote control
- Wireless outside temperature sensor

For max. 3 wireless remote controls. Not in conjunction with a hard-wired remote control.

Connection:

- Two-core cable, length max. 50 m (even if connecting several KM BUS subscribers).
- Never route this cable immediately next to 230/400 V cables.

Specification

Power supply via KM BUS
Power consumption
Wireless frequency
Wireless protocol
Safety category
IP rating

1 W
868.3 MHz
EnOcean
III
IP 20 to EN 60721
Ensure through design/installation

Permissible ambient temperature
– during operation
– during storage and transportation

0 to +40 °C
–20 to +65 °C

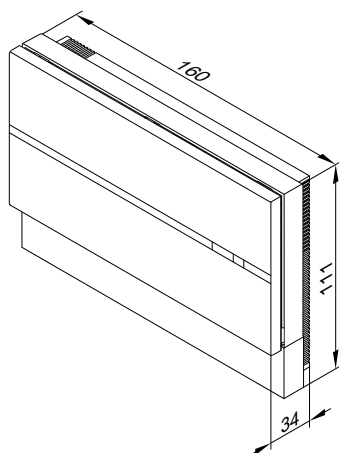

Wireless outside temperature sensor

Part no. 7455 213

Wireless subscriber.

Wireless, light activated outside temperature sensor with integral wireless transmitter for operation with a wireless base station and the Vitotronic control unit.

Installation site:

- North or north-western wall of the building
- 2 to 2.5 m above the ground, for multi storey buildings in the upper half of the second floor

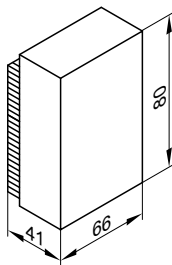

Specification

PV cells and an energy store provide the power supply
Radio frequency
Wireless protocol
Wireless range

868.3 MHz
EnOcean
See "Wireless accessories" technical guide

Control units (cont.)

IP rating	IP 43 acc. to EN 60529 ensure through appropriate design/installation
Permissible ambient temperature during operation, storage and transport	-40 to +60 °C

Wireless repeater

Part no. 7456 538

Mains operated repeater to increase the wireless range and for use in areas where wireless communication is difficult. Refer to "Wireless accessories" technical guide.

Max. one wireless repeater per Vitotronic control unit.

- Avoid over-diagonal angle of penetration of the radio signals through iron reinforced concrete ceilings and/or through multiple walls.
- Avoid large metallic objects between the wireless components.

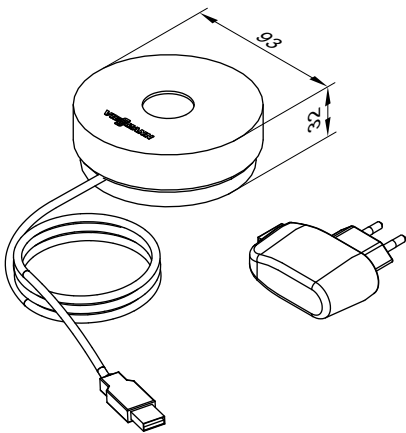

Specification

Power supply via plug-in power supply unit	230 V~/5 V-
Power consumption	0.25 W
Wireless frequency	868.3 MHz
Wireless protocol	EnOcean
Lead length	1.1 m with plug
Safety category	II
IP rating	IP 20 acc. to EN 60529 Ensure through design/installation
Permissible ambient temperature	
– during operation	0 to +55 °C
– during storage and transportation	-20 to +75 °C

Room temperature sensor

Part no. 7438 537

Separate room temperature sensor as supplement to the Vitotrol 300A; to be used if the Vitotrol 300A cannot be installed inside the main living room or in a suitable position where the unit could capture and adjust the temperature.

Installation in the main living room on an internal wall opposite radiators. Never install inside shelving units, in recesses, or immediately by a door or heat source (e.g. direct sunlight, fireplace, TV set, etc.).

Connect the room temperature sensor to the Vitotrol 300A.

Connection:

- 2-core lead with a cross-section of 1.5 mm² (copper)
- Lead length from the remote control up to 30 m
- Never route this lead immediately next to 230/400 V cables

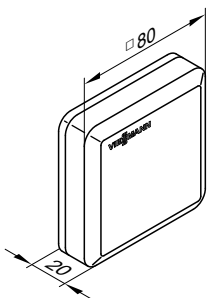

Specification

Safety category	III
IP rating	IP 30 acc. to EN 60529 Ensure through design/installation
Sensor type	Viessmann NTC 10 kΩ at 25 °C
Permissible ambient temperature	
– during operation	0 to +40 °C
– during storage and transportation	-20 to +65 °C

Contact temperature sensor

Part no. 7426 463

To capture the temperature on a pipe.

Control units (cont.)

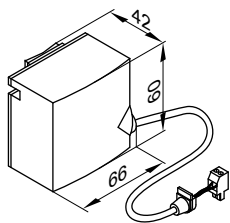

Specification

Lead length	5.8 m, fully wired
IP rating	IP 32D to EN 60529 Ensure through design/installation
Sensor type	Viessmann NTC 10 kΩ at 25 °C
Permissible ambient temperature	
– During operation	0 to +120 °C
– During storage and transport	–20 to +70 °C

Secured with a tie.

Immersion temperature sensor

Part no. 7438 702

To capture a temperature in a sensor well.

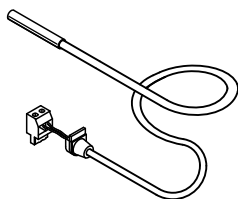

Specification

Lead length	5.8 m, fully wired
IP rating	IP 32 to EN 60529; ensure through design/installation
Sensor type	Viessmann NTC 10 kΩ, at 25 °C
Permissible ambient temperature	
– during operation	0 to +90 °C
– during storage and transport	–20 to +70 °C

Sensor well

Part no. 7816 035

G½ x 100 mm.

With retaining clip.

Sensor well

Part no. 7817 326

G½ x 150 mm.

With retaining clip.

Sensor well

Part no. 7819 693

R ½" x 200 mm

For the cylinder temperature sensor, part of the standard delivery of Viessmann DHW cylinders.

Flue gas temperature sensor

Part no. 7452 531

For scanning the flue gas temperature, flue gas temperature monitoring and maintenance indication, if the set temperature has been exceeded.

With threaded cone.

Installation on the flue pipe. The distance from the boiler must be approx. 1.5 times the flue pipe diameter, measured from the boiler edge (back) to the chimney stack.

- Condensing boilers with Viessmann balanced flue system:
Order the balanced flue pipe with connector for the flue gas temperature sensor separately.
- For condensing boilers with on-site flue pipe:
The aperture required for the flue pipe installation must be designed and approved on site. Install the flue gas temperature sensor into a stainless steel sensor well (on-site provision).

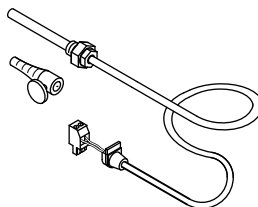

Specification

Lead length	3.5 m, fully wired
IP rating	IP 60 to EN 60529; ensure through design/installation
Sensor type	Viessmann NTC 20 kΩ, at 25 °C
Permissible ambient temperature	
– during operation	0 to +250 °C
– during storage and transport	–20 to +70 °C

Control units (cont.)

Cylinder temperature sensor

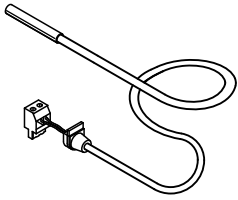

Specification

Lead length	5.8 m, fully wired
IP rating	IP 32 to EN 60529; ensure through design/installation
Sensor type	Viessmann NTC 10 kΩ, at 25 °C
Permissible ambient temperature	
– during operation	0 to +90 °C
– during storage and transport	–20 to +70 °C

Mixer extension kit

Part no. 7441 998

Components:

- Mixer motor with connecting cable (4.0 m long) for Viessmann mixer DN 20 to 50 and R ½ to 1¼ (not for flanged mixer) and plug
- Flow temperature sensor as contact temperature sensor with connecting cable (5.8 m long) and plug
- Plug for heating circuit pump

Mixer motor

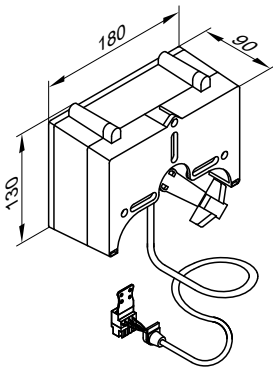

Specification

Rated voltage	230 V~
Rated frequency	50 Hz
Power consumption	4 W
Safety category	II
IP rating	IP42 to EN 60529; ensure through design/installation

Permissible ambient temperature

– During operation	0 to +40 °C
– During storage and transport	–20 to +65 °C
Torque	3 Nm
Runtime for 90 ° <	120 s

Flow temperature sensor (contact sensor)

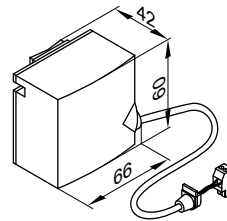

Secured with a tie.

Specification

IP rating	IP32D to EN 60529 ensure through design/installation
Sensor type	Viessmann NTC, 10 kΩ at 25 °C
Permissible ambient temperature	
– During operation	0 to +120 °C
– During storage and transport	–20 to +70 °C

Mixer motor for flanged mixers

- **Part no. 9522 487**
DN 40 and 50, without system plug and connecting cable
- **Part no. Z004344**
DN 65 to 100, without system plug and connecting cable

For specification, see the "Mixer and mixer motors" datasheet.

Plug 20

Part no. 7415 056

for heating circuit pump

Plug 52

Part no. 7415 057

for mixer motors

Plugs for sensors

Part no. 7268 274

Immersion thermostat

Part no. 7151 728

May be used as a maximum temperature limiter for underfloor heating systems.

The temperature limiter is installed into the heating flow and switches the heating circuit pump OFF if the flow temperature is too high.

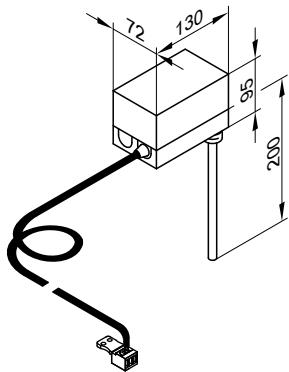

Specification

Lead length	4.2 m, fully wired
Setting range	30 to 80 °C
Switching differential	max. 11 K
Breaking capacity	6(1.5) A 250 V~
Setting scale	inside the casing
Stainless steel sensor well	R ½" x 200 mm
DIN reg. no.	DIN TR 116807 or DIN TR 96808

Contact thermostat

Part no. 7151 729

May be used as a maximum temperature limiter for underfloor heating systems (only in conjunction with metallic pipes).

The temperature limiter is installed into the heating flow and switches the heating circuit pump OFF if the flow temperature is too high.

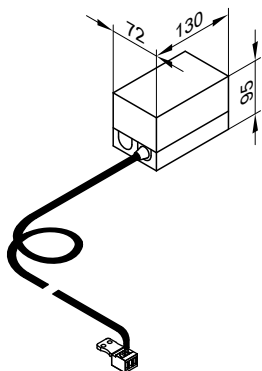

Specification

Lead length	4.2 m, fully wired
Setting range	30 to 80 °C
Switching differential	max. 14 K
Breaking capacity	6(1.5) A 250V~
Setting scale	inside the casing
DIN reg. no.	DIN TR 116807 or DIN TR 96808

Radio clock receiver

Part no. 7450 563

For receiving the DCF 77 time signal (location: Mainflingen near Frankfurt/Main).

Radio controlled setting of time and date.

Install on an outside wall, facing the transmitter. The reception may be reduced by metallic elements in the building structure, e.g. steel reinforced concrete, neighbouring buildings and sources of electro-magnetic interference, e.g. HV and public transport lines.

Connection:

- 2-core lead, length up to 35 m with a cross-section of 1.5 mm²(copper)
- Never route this lead immediately next to 230/400 V cables.

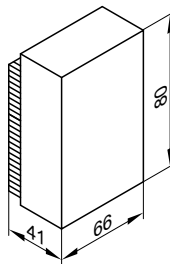

Plug-in adaptor for external safety equipment

Part no. 7164 404

KM BUS subscriber

With cables (3.0 m long) and plugs 145 and 150.

Up to 4 additional pieces of safety equipment may be connected, for example:

- Low water indicator
- Minimum pressure limiter



Control units (cont.)

- Maximum pressure limiter
- Additional high limit safety cut-out

The plug-in adaptor enables the fault (plain text) to be displayed in the relevant control unit.

Two plug-in adaptors can be linked together via the KM BUS and connected to the control unit. This makes it possible to connect 7 additional safety features.

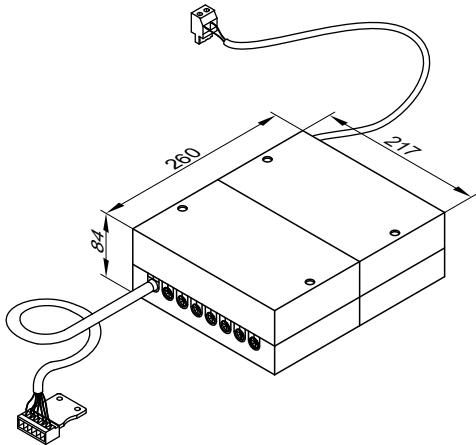

Specification

IP rating

IP 20D to EN 60529; ensure through design/installation

Permissible ambient temperature

– during operation

0 to +40 °C

– during storage and transport

–20 to +65 °C

Contactor relay

Part no. 7814 681

Contactor in small casing.

With 4 N/C and 4 N/O contacts.

With terminal strip for earth conductors.

Specification

Coil voltage

230 V~/50 Hz

Rated current (I_{th})

AC1 16 A

AC3 9 A

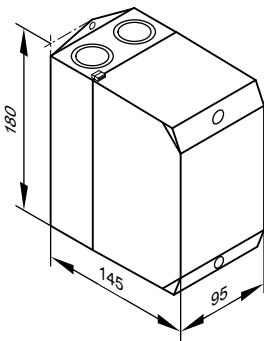

Mating plugs 41 and 90

Part no. 7408 790

Required for an on-site burner without mating plug.

Mounting kit for control panel fitting

Part no. 7452 236

To install the programming unit section of the control unit in the front door of the control panel (if the control unit is to be installed in a control panel).

A cut-out inside the front door of the control panel measuring 305 x 129 mm is required for its installation.

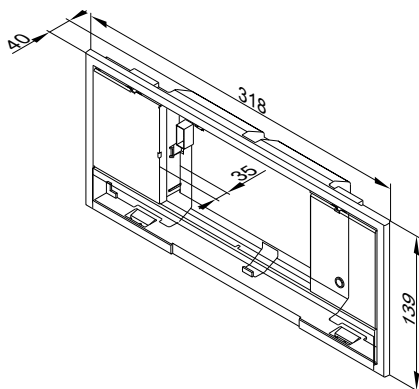

Components:

- Mounting frame
- Dummy cover for installation in the control unit
- Connecting cable (5.0 m long)
- Elbow plug for connecting cable

Solar control module, type SM1

Part no. 7429 073

Specification

Construction

The solar control module contains:

- PCB
- Terminals:
 - 4 sensors
 - Solar circuit pump
 - KM BUS
 - Power supply (on-site ON/OFF switch)
- PWM output for controlling the solar circuit pump
- 1 relay for switching a pump or a valve

Collector temperature sensor

For connection inside the appliance.

On-site extension of the connecting lead:

- 2-core lead, length up to 60 m with a cross-section of 1.5 mm² (copper)
- Never route this lead immediately next to 230/400 V cables

Lead length	2.5 m
IP rating	IP 32 to EN 60529; ensure through design/installation
Sensor type	Viessmann NTC 20 kΩ at 25 °C

Permissible ambient temperature	
– during operation	–20 to +200 °C
– during storage and transport	–20 to +70 °C

Cylinder temperature sensor

For connection inside the appliance.

On-site extension of the connecting lead:

- 2-core lead, length max. 60 m with a cross-section of 1.5 mm² (copper)
- Never route this lead immediately next to 230/400 V cables

Lead length	3.75 m
IP rating	IP 32 to EN 60529; ensure through design/installation
Sensor type	Viessmann NTC 10 kΩ at 25 °C

Permissible ambient temperature	
– during operation	0 to +90 °C
– during storage and transport	–20 to +70 °C

For systems with Viessmann DHW cylinders, the cylinder temperature sensor is installed in the threaded elbow (standard delivery or accessory for the respective DHW cylinder) in the heating water return.

Functions

- Switching the solar circuit pump
- Solar circuit pump speed control via wave packet control or solar circuit pump with PWM input (Grundfos)
- Electronic limiter for the temperature in the DHW cylinder (safety shutdown at 90 °C)
- Collector safety shutdown
- Switching an additional pump or valve via relay
- Central heating backup is controlled in conjunction with a multi mode heating water buffer cylinder
- Second differential temperature control, thermostat function or auxiliary function for DHW heating
- Suppression of DHW cylinder reheating by the boiler
- Suppression of reheating by the boiler with central heating backup
- Output statement and diagnostic system

The immersion temperature sensor, part no. 7438 702 is required if the following functions should be realised:

- Transfer for systems with two DHW cylinders
or
- Return changeover between the boiler and the heating water buffer cylinder

Specification

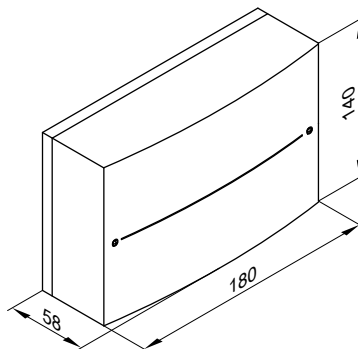

Rated voltage	230 V~
Rated frequency	50 Hz
Rated current	2 A
Power consumption	1.5 W
Safety category	I
IP rating	IP 20 to EN 60529; ensure through design/installation
Function	Type 1 B to EN 60730-1

Control units (cont.)

Permissible ambient temperature
– during operation

– during storage and transport

0 to +40 °C use in the living space or boiler room (standard ambient conditions)
–20 to +65 °C

Rated relay output breaking capacity

– Semi-conductor relay 1 1 (1) A, 230 V~
– Relay 2 1 (1) A, 230 V~
– Total max. 2 A

Extension AM1

Part no. 7452 092

Function extension inside the casing for wall mounting.

Up to 2 of the following pumps can be controlled:

- Flue gas heat exchanger
- Heating circuit pump (multi stage) for the heating circuit without mixer.
- Neutralisation

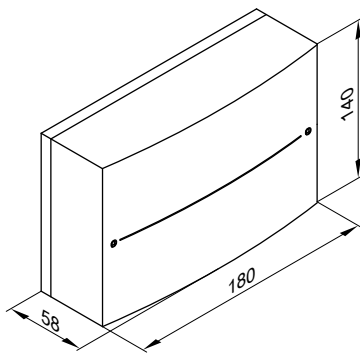

Specification

Rated voltage 230 V~
Rated frequency 50 Hz
Rated current 4 A
Power consumption 4 W
Rated relay output breaking capacity Each 2(1) A 250 V~
Total max. 4 A~
Safety category I
IP rating IP 20 D to EN 60529
ensure through design/installation

Permissible ambient temperature

– during operation 0 to +40 °C
Installation in living spaces or boiler rooms (standard ambient conditions)
– during storage and transport –20 to +65 °C

Extension EA1

Part no. 7452 091

Function extension inside the casing for wall mounting.

Using the inputs and outputs allows up to 5 functions to be achieved:

1 switching output (floating changeover contact)

- Switching a feed pump to a substation
- Signalling reduced mode for a heating circuit

1 analogue input (0 to 10 V)

- Set boiler water temperature default

3 digital inputs

- External operating mode changeover for 1 to 3 heating circuits (only with control units for weather-compensated mode)
- External blocking with central fault message
- Fault messages
- Brief operation of the DHW circulation pump (only with control units for weather-compensated mode)

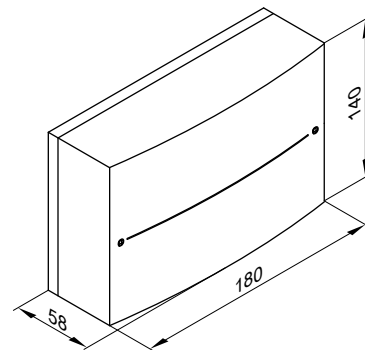

Specification

Rated voltage 230 V~
Rated frequency 50 Hz
Rated current 2 A
Power consumption 4 W
Rated breaking capacity of the relay output 2(1) A 250 V~
Safety category I
IP rating IP 20 D to EN 60529
ensure through appropriate design/installation

Permissible ambient temperature

– during operation 0 to +40 °C
Installation in living spaces or boiler rooms (standard ambient conditions)
– during storage and transport –20 to +65 °C

Vitocom 100, type LAN1

With communication module

Part no. Z011 224

Without communication module

Part no. Z011 389

For remote control of a heating system via internet and IP networks (LAN) with DSL router.

Compact unit for wall mounting.

For system operation with **Vitotrol app** or **Vitodata 100**.

Functions when operating with Vitotrol app:

- Remote control of up to three heating circuits in one heating system.
- Adjusting operating programs, set values and time programs via iPhone, iPad or iPod with Retina Display with operating system iOS 4.3/5.
- Scanning system information
- Displaying messages on the user interface of the Vitotrol app

Note

For more information, see "www.vitotrol-App.info".

Functions when operating with Vitodata 100:

Remote monitoring of all heating circuits in a heating system:

- Forwarding messages via email to PC/smartphone (email client function required)
- Forwarding messages via SMS to mobile phone/smartphone or fax (via chargeable internet service Vitodata 100 fault management)

Remote control:

Adjusting operating programs, set values, time programs and heating curves

Configuration:

Configuration takes place automatically.

When the DHCP service is enabled, no adjustments have to be made on the DSL router.

Standard delivery:

- Vitocom 100, type LAN1 with LAN connection
- LON communication module
- Connecting cables for LAN and communication module LON
- Power cable with plug-in power supply unit
- Vitodata 100 fault management for a duration of 3 years

On-site requirements:

The LON communication module must be installed in the control unit.

Before commissioning, check the system requirements for communication via the IP networks (LAN).

Internet connection with flat rate data (**without** time or volume restrictions)

Note

For further information on registering and using the *Vitotrol app* and *Vitodata 100*, see "www.vitodata.info".

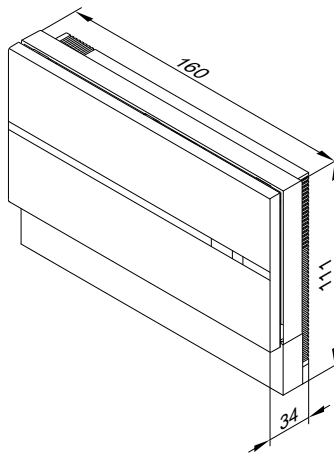

Specification

Power supply via plug-in power supply unit 230 V~/5 V-

Rated current 1.6 A

Power consumption 8 W

Safety category II

IP rating IP 30 to EN 60529; ensure through design/installation

Permissible ambient temperature – during operation

0 to +55 °C

– during storage and transport

Use in the living space and in boiler rooms (standard ambient conditions)
–20 to +85 °C

Vitocom 100, type GSM

■ Without SIM card

Part no. Z004594

■ With contract SIM card for the operation of the Vitocom 100 via mobile phone

Part no. Z004615

Note

For information regarding terms of contract, see "www.viessmann.de/vitocom-100".

Functions:

- Remote switching via GSM mobile phone networks
- Remote scanning via GSM mobile phone networks
- Remote monitoring via SMS to 1 or 2 mobile phones
- Remote monitoring of additional systems via digital input (230 V)

Configuration:

Mobile phones via SMS

Standard delivery:

- Vitocom 100 (subject to order with or without SIM card)
- Power cable with standard Euro plug (2.0 m long)
- GSM aerial (3.0 m long), magnetic foot and adhesive pad
- KM BUS cable (3.0 m long)

On-site requirements:

Good reception for GSM communication with the selected mobile phone operator.

Total length of all KM BUS subscriber cables up to 50 m.

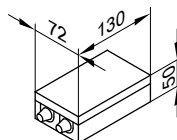

Control units (cont.)

Specification

Rated voltage	230 V ~
Rated frequency	50 Hz
Rated current	15 mA
Power consumption	4 W
Safety category	II
IP rating	IP 41 to EN 60529; ensure through design/installation
Function	Type 1B to EN 60 730-1

Permissible ambient temperature

– during operation	0 to +55 °C
	Installation in living spaces or boiler rooms (standard ambient conditions)
– during storage and transport	–20 to +85 °C
On-site connection	
Fault input DE 1	230 V ~

Vitocom 200, type GP1

For part no., see the current pricelist

- With integral GPRS modem.
- With D2 SIM card.
- For **one** heating system with one or more heat sources, with or without heating circuits downstream.
- For remote monitoring and remote setting of heating systems via mobile phone.

In conjunction with Vitodata 100

- For remote signalling, monitoring and scanning of faults and/or data points via the internet
- Remote switching of the heating systems via the internet

Configuration

The Vitocom 200 is configured via Vitodata 100. The pages for the Vitodata 100 user interface are created automatically during commissioning.

Fault messages

Fault messages are transmitted via the following communication services to the configured control devices:

- Text messages (SMS) to mobile phones
- Email to PC/laptop

On-site requirements:

- Adequate GPRS radio signal for the D2 [Vodafone] mobile network at the location where the Vitocom 200 is installed
- LON communication module must be installed in the Vitotronic appliance

Note

For information on the terms and conditions of use and contract, see Viessmann pricelist and "www.viessmann.de/vitocom-200-GP".

Standard delivery:

- Power cable (2 m long) with plug
- Aerial with 3 m connecting cable, magnetic foot and adhesive pad
- SIM card
- LON connecting cable RJ45 – RJ45, 7 m long, for data exchange between the Vitotronic and Vitocom 200

Note

For standard delivery of packs with Vitocom, see pricelist.

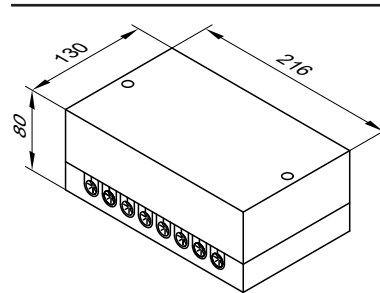

Specification

Rated voltage	230 V ~
Rated frequency	50 Hz
Rated current	22 mA
Power consumption	5 VA
Safety category	II to EN 61140
IP rating	IP 20 to EN 60529; ensure through design/installation
Function	Type 1B to EN 60730-1

Permissible ambient temperature

– during operation	0 to +50 °C
	Installation in living spaces or boiler rooms (standard ambient conditions)
– during storage and transport	–20 to +85 °C

On-site connections:

– 2 digital inputs DE 1 and DE 2	Floating contacts, two-pole, 24 V–, 7 mA
– 1 digital output DA1	Floating relay contact, 3-pole, changeover contact, 230 V~/30 V–, max. 2 A

For further technical details and accessories, see the data communication technical guide.

For extended functions, operation with the Vitodata 300 user interface is also possible; see the data communication technical guide.

Vitocom 300, type FA5, FI2, GP2

For part no., see the current pricelist

- Type FA5 with integral analogue modem
- Type FI2 with integral ISDN modem
- Type GP2 with integral GPRS modem
- For **up to 5** heating systems with one or more heat sources, with or without heating circuits downstream.

In conjunction with Vitodata 300

- For remote signalling, monitoring and scanning of faults and/or data points via the internet
- For remote switching, remote setting of parameters and codes for heating systems via the internet

Configuration

The Vitocom 300 is configured via the Vitodata 300.

Control units (cont.)

Fault messages

Fault messages are reported to the Vitodata 300 server. These messages are transmitted via the following communication services from the Vitodata 300 server to the configured recipients:

- Fax
- Text messages (SMS) to mobile phones
- Email to PC/laptop

On-site requirements:

- Telephone connection
 - Type FA5: Thermally activated shut-off equipment socket, code "6N"
 - Type FI2: RJ45 socket (ISDN)
- Type GP2: Adequate GPRS radio signal for the D2 [Vodafone] mobile network at the location where the Vitocom 300 is installed
- LON communication module must be installed in the Vitotronic appliance

Note

For further information regarding the terms of contract, see the Viessmann pricelist.

Standard delivery:

- Standard module^{*17} (with 8 digital inputs, 1 digital output and 2 analogue sensor inputs)
 - Type FA5: with integral analogue modem, Connecting cable for telephone socket TAE 6N, 2 m long
 - Type FI2: with integral ISDN modem, Connecting cable with RJ45 plug for ISDN socket, 3 m long
 - Type GP2: with integral GPRS modem, Aerial with connecting cable, 3 m long SIM card
- LON connecting cable RJ45 – RJ45, 7 m long, for data exchange between the Vitotronic and Vitocom 300
- Power supply unit^{*17}
- Power cable from the power supply unit to the standard module

Note

For standard delivery of packs with Vitocom, see pricelist.

Accessories:

Accessories	Part no.
Wall mounting enclosure for the installation of the Vitocom 300 module, if no control panel or electrical distribution panel is available	
2 rows	7143 434
3 rows	7143 435
Extension module ^{*17}	
– 10 digital inputs (8 potential-free, two 230 V~)	7143 431
– 7 analogue inputs (2 can be configured as pulsed inputs)	
– 2 digital outputs	
– See the standard module for dimensions	
or	
– 10 digital inputs (8 potential-free, two 230 V~)	7159 767
– 7 analogue inputs (2 can be configured as pulsed inputs)	
– 2 digital outputs	
– 1 M BUS interface with connection of up to, for example, 16 M BUS capable heat meters with M BUS slave interface to EN 1434-3	
– See the standard module for dimensions	

Accessories	Part no.
Uninterruptible power supply unit ^{*17} (UPS)	7143 432
Additional rechargeable battery pack ^{*17} for UPS	
– Recommended with 1 basic module, 1 extension module and all inputs allocated	7143 436
– Required with: 1 standard module and 2 extension modules	
Extension of the connecting cable	
Spacing 7 to 14 m	
– 1 connecting cable (7 m long) and 1 LON coupling RJ45	7143 495 and 7143 496
Spacing 14 to 900 m with plug-in connector	
– 2 LON plug-in connectors RJ45 and 2-core cable, CAT5, screened, solid cable, AWG 26-22, 0.13 to 0.32 mm ² , external diameter, 4.5 to 8 mm	7199 251 and On-site or On-site
or	
– 2-core cable, CAT5, screened, wire, AWG 26-22, 0.14 to 0.36 mm ² , external diameter, 4.5 to 8 mm	
Spacing 14 to 900 m with socket	
– 2 connecting cables (7 m long) and 2 LON sockets RJ45, CAT6	7143 495 and 7171 784
– 2-core cable, CAT 5, screened or JY(St) Y 2 x 2 x 0.8	On-site or On-site

Standard module (standard delivery):

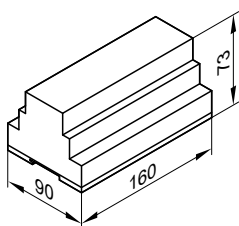

Specification

Rated voltage	24 V –
Rated current	
– Type FA5	600 mA
– Type FI2	500 mA
– Type GP2	500 mA
Safety category	II to EN 61140
IP rating	IP 20 to EN 60529
Function	Ensure through appropriate design/installation Type 1B to EN 60730-1
Permissible ambient temperature	
– During operation	0 to +50 °C Installation in living spaces or boiler rooms (standard ambient conditions)
– During storage and transport	–20 to +85 °C
On-site connections:	
– 8 digital inputs DE 1 to DE 8	Floating contact, 2-pole, 24 V–, max. 7 mA
– 1 digital output DA1	Floating relay contact, 3-pole, changeover contact, 230 V~/30 V–, max. 2 A
– 2 analogue inputs AE 1 and AE 2	For Viessmann Ni500 temperature sensors, 10 to 127 °C ±0.5 K

^{*17} Mounting rail installation TS35 to DIN EN 50 022, 35 x 15 and 35 x 7.5.

Control units (cont.)

Power supply unit (standard delivery):

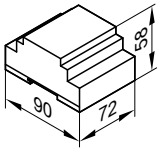

Specification

Rated voltage	85 to 264 V ~
Rated frequency	50/60 Hz
Rated current	0.55 A
Output voltage	24 V –
Output current	1.5 A
Safety category	II to EN 61140
IP rating	IP 20 to EN 60529
	Ensure through appropriate design/installation

Potential separation

primary/secondary

Electrical safety

Permissible ambient temperature

– For operation with supply voltage U_E
187 to 264 V

– For operation with supply voltage U_E
100 to 264 V

– During storage and transport

For further technical details and accessories, see the data communication technical guide.

SELV to EN 60950

EN 60335

–20 to +55 °C

Installation in living spaces or boiler rooms (standard ambient conditions)

–5 to +55 °C

Installation in living spaces or boiler rooms (standard ambient conditions)

–25 to +85 °C

LON connecting cable for data exchange between control units

Part no. 7143 495

Cable length 7 m, fully wired (RJ 45).

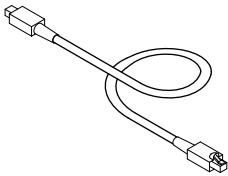

Extension of the connecting cable

- Installation spacing 7 to 14 m:
 - 2 connecting cables (7.0 m long)
Part no. 7143 495
 - 1 LON coupling RJ45
Part no. 7143 496
- Installation distance 14 to 900 m with plug-in connectors:
 - 2 LON plug-in connectors
Part no. 7199 251
 - 2-core cable:
 - CAT5, screened
 - or
 - Solid conductor AWG 26-22 / 0.13 mm² - 0.32 mm²,
 - Conductor AWG 26-22 / 0.14 mm² - 0.36 mm²
 - ∅ 4.5 mm - 8 mm
 - on-site**
- Installation distance 14 to 900 m with junction boxes:
 - 2 connecting cables (7.0 m long)
Part no. 7143 495
 - 2-core cable:
 - CAT5, screened
 - or
 - Solid conductor AWG 26-22 / 0.13 mm² - 0.32 mm²,
 - Conductor AWG 26-22 / 0.14 mm² - 0.36 mm²
 - ∅ 4.5 mm - 8 mm
 - on-site**
 - 2 LON sockets RJ45, CAT6
Part no. 7171 784

Terminator (2 pce)

Part no. 7143 497

For terminating the LON BUS at the first and last control unit.

LON communication module

Part no. 7172 173

(Only for single boiler systems)

PCB for data exchange with the heating circuit control units Vitotronic 200-H, Vitocom 300 and for connection to a higher ranking building management system.

For the connecting cables, see section "Vitocom".

11.7 Vitogate 200, type EIB

Part no. Z009 466

The Vitogate 200 type EIB gateway is designed to hook up Vitotronic control units with integral LON communication module (accessory) to KNX/EIB systems.

For specification and accessories, see the data communication technical guide.

11.8 On-site connections

Additional functions for single boiler systems with a Vitotronic 200, type GW1B

Connection of on-site control units for weather-compensated mode to the extension EA1

External demand via 0 – 10 V input

Connection to the 0 – 10 V input on the **extension EA1**. In conjunction with a two-stage or modulating burner.

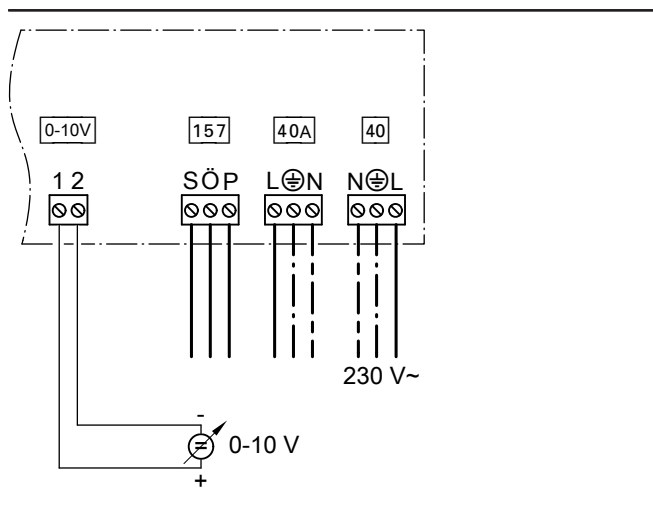

0 - 1 V ≙ "No default set boiler water temperature"
 Default temperature for the boiler:
 Range of 0 to 100 °C (can be changed to 30 to 120 °C)
 1 V ≙ set value 10 °C (30 °C)
 10 V ≙ set value 100 °C (120 °C)

Note

Ensure DC separation between the negative pole and the earth conductor of the on-site voltage source.

Digital data inputs DE1 to DE3

Functions:

- External changeover of the operating status, separate for heating circuits 1 to 3
- External blocking with fault message input
- Fault message input
- Brief operation of the DHW circulation pump

The hooked-up contacts must correspond to safety category II.

Input function assignment

Select the input functions via the codes on the boiler control unit:

- DE1: Coding address "5d"
- DE2: Coding address "5E"
- DE3: Coding address "5F"

Set flow temperature for external demand

- The set flow temperature can be selected with code 9b.

Output 157

Connections:

- Switching a feed pump to a substation
- Signalling reduced mode for a heating circuit

Function assignment

Select the function of output 157 via coding address "5C".

Plug 143

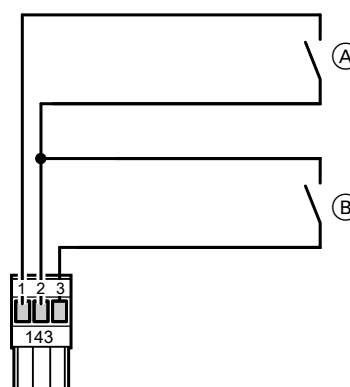

- (A) External heating program changeover/mixer "open"
- (B) External blocking/mixer "close"

(A) and (B) are floating contacts.

External heating program changeover/mixer "open"

Closing contact (A) can change the manually selected heating program or open the connected mixers. In coding address "9A", the external function mixer "open" can be allocated to the individual heating circuits.

Control units (cont.)

In coding address "91", the external heating program changeover can be allocated to the heating circuits.

Heating programs

Symbol	Explanation
⊖	Central heating OFF and DHW OFF
⊖	Central heating OFF and DHW ON
⊖	Central heating ON and DHW ON

Subject to the setting of coding address "d5", the system can be switched over from all three manually adjustable heating programs ⊖, ⊖ and ⊖ (contact open), to either ⊖ or ⊖ (contact closed).

External blocking/mixer "close"

Closing contact (B) causes the burner to shut down or the mixer to be closed.

In coding address "99" you select which heating circuits are affected by the function external blocking or mixer "close".

Note

The frost protection of the relevant boiler or heating circuit is no longer effective during the controlled shutdown or when the mixer "Closes". The lower boiler water temperature or flow temperature will no longer be maintained.

Plug 146

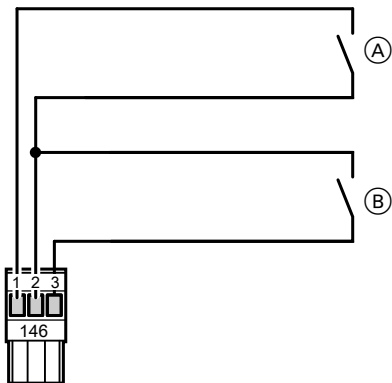

- (A) External changeover of stepped/modulating burners
- (B) External demand

(A) and (B) are floating contacts.

External demand

Closing contact (B) starts the burner of the boiler subject to load. The boiler water temperature is limited via the maximum set boiler water temperature or via the mechanical control thermostat. The set value is selected in coding address "9b".

External changeover of multi stage/modulating burners

- Contact (A) open:
 - Modulating operation
 - Contact (A) closed:
 - Two-stage operation
- Set coding address "02" accordingly.

Additional functions for multi boiler systems with Vitotronic 300-K, type MW1B or Vitotronic 100, type GC1B via LON

Plugs 143 and 146 at the Vitotronic 300-K

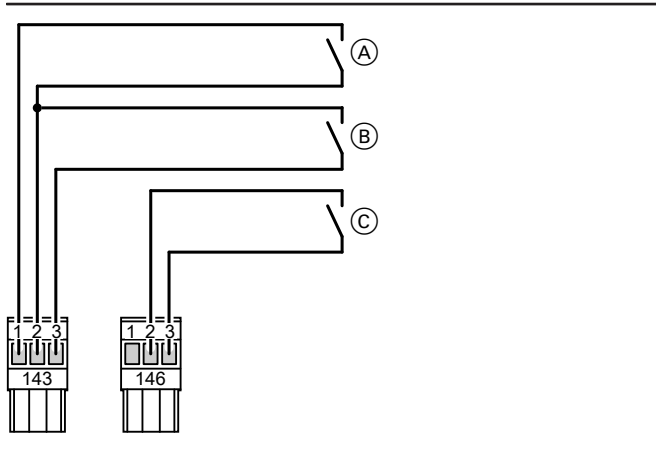

- (A) External heating program changeover/mixer "open"
- (B) External blocking/mixer "closed"
- (C) External demand

(A), (B) and (C) are floating contacts.

External heating program changeover/mixer "open"

Closing contact (A) can change the manually selected heating program or open the connected mixers. In coding address "9A", the external function mixer "open" can be allocated to the individual heating circuits. In coding address "91", the external heating program changeover can be allocated to the heating circuits.

Heating programs

Symbol	Explanation
☐	Central heating OFF and DHW OFF
☐➔	Central heating OFF and DHW ON
☐☐☐➔	Central heating ON and DHW ON

Subject to the setting of coding address "d5", the system can be switched over from all three manually adjustable heating programs ☐, ☐➔ and ☐☐☐➔ (contact open), to either ☐ or ☐☐☐➔ (contact closed).

External blocking/mixer "closed"

Closing contact (B) causes the burner to shut down or the mixer to be closed. In coding address "99" you select which heating circuits are affected by the function external blocking or mixer "close".

Note

The frost protection of the relevant boiler or heating circuit is no longer effective during the controlled shutdown or when the mixer "Closes". The lower boiler water temperature or flow temperature will no longer be maintained.

External demand

Closing contact (C) starts the burner or boiler subject to load. The boiler water temperature is limited via the maximum set boiler water temperature or via the mechanical control thermostat. The set value is selected in coding address "9b".

Plug 143 at the Vitotronic 100, type GC1

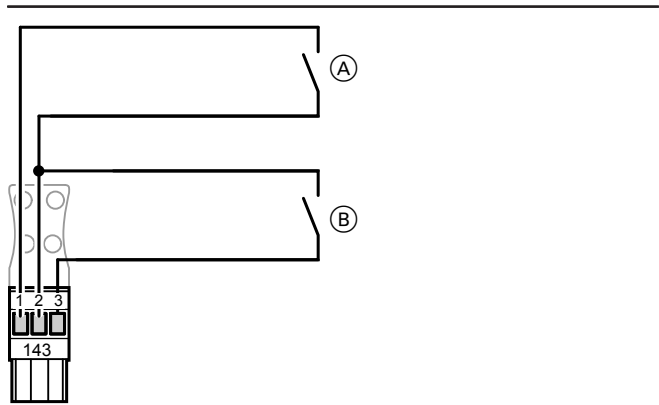

- (A) Boiler blocking
- (B) Start boiler as the last one in the boiler sequence

(A) and (B) are zero volt contacts.

Boiler blocking

■ Contact (A) closed: The boiler is blocked and removed from the boiler sequence, i.e. the butterfly valve or the three-way mixing valve for constant return temperature control is closed; shunt or boiler circuit pumps are switched OFF. The other boilers must provide the required heating.

Note

The heating system is **no longer protected against frost** if all boilers are blocked or when there are no other available boilers.

■ Contact (A) open: The boiler is reinstated into the current boiler sequence.

Start boiler as the last one in the boiler sequence

■ Contact (B) closed: The boiler is started as the last one in the boiler sequence. The heat demand of the heating system is being met by the other boilers. This boiler is started if the output of the other boilers is inadequate.
 ■ Contact (B) open: The boiler is returned into the current boiler sequence.

Connection of on-site control units to extension EA1 in single boiler systems

Control via 0 – 10 V interface

External demand via 0 – 10 V input

Connection to the 0 – 10 V input on the extension EA1. In conjunction with a two-stage or modulating burner. Code "01:1" for single boiler system (delivered condition).

11

Control units (cont.)

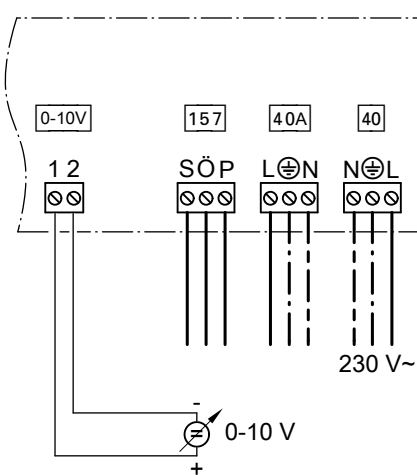

0 - 1 V $\hat{=}$ "No default set boiler water temperature"
 Default temperature for the boiler:
 Range of 0 to 100 °C (can be changed to 30 to 120 °C)
 1 V $\hat{=}$ set value 10 °C (30 °C)
 10 V $\hat{=}$ set value 100 °C (120 °C)

Note

Ensure DC separation between the negative pole and the earth conductor of the on-site voltage source.

Digital data inputs DE1 to DE3

Functions:

- External blocking with fault message input
- Fault message input

The hooked-up contacts must correspond to safety category II.

Input function assignment

Select the input functions via the codes on the boiler control unit:

- DE1: Coding address "5d"
- DE2: Coding address "5E"
- DE3: Coding address "5F"

Set flow temperature for external demand

- The set flow temperature can be selected with code 9b.

Output 157

Function assignment

Select the function of output 157 via coding address "5C".

Connection of on-site control units to the Vitotronic 100, type GC1B, in single boiler systems

Switching via contacts

Operation with a two-stage burner

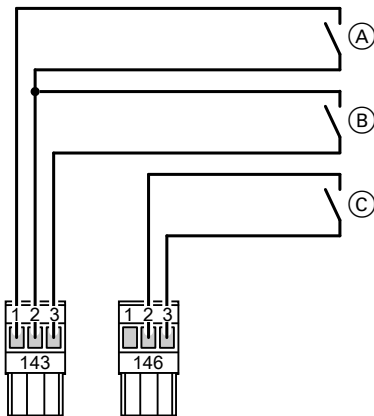

- (A) Burner stage 1 "on"
- (B) Burner stage 2 "on"
- (C) External load-dependent starting

(A), (B) and (C) are floating contacts of the higher ranking control unit.

External burner start – burner stage 1

Contact at terminals "1" and "2" of plug 143

- Contact closed:
 Burner stage 1 is switched ON.
 Burner stage 2 is switched ON only for maintaining the minimum temperature.
 The boiler water temperature is limited by the electronic maximum temperature limiter (see the Vitotronic 100 service instructions), if it is set below that of mechanical thermostat "⊕".
- Contact open:
 Burner stage 1 is switched OFF.

External burner start – burner stage 1 and 2

Contact at terminals "2" and "3" of plug 143

- Contact closed:
 Both burner stages are switched ON.
 The boiler water temperature is limited by the electronic maximum temperature limiter, if it is set below that of mechanical control thermostat "⊕".
 Burner stage 2 is switched OFF 2 K sooner.
- Contact open:
 Burner stages 1 and 2 are switched OFF.

External starting subject to load

The burner is started, subject to load, when the zero volt contact across terminals "2" and "3" at plug-in connector 146 closes.
 The boiler will be constantly operated at the set temperature.
 The boiler water temperature is limited via the maximum set boiler water temperature or via the mechanical control thermostat.
 The set value is adjusted via code "9b".

Control units (cont.)

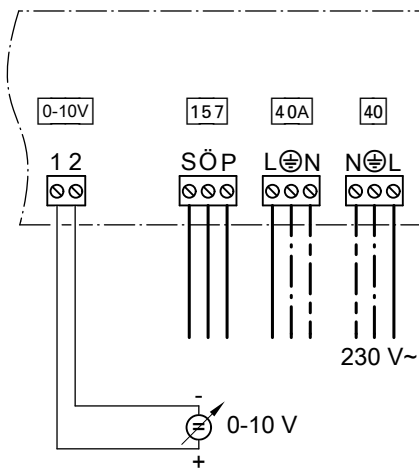

Enable boiler without an additional enable contact

0 to 1 V

- Boiler blocked.
- Butterfly valve closed.
- Boiler circuit pump or shunt pump off.

1 to 10 V

- Default temperature for the boiler:
Range of 0 to 100 °C (can be changed to 30 to 120 °C)
1 V $\hat{=}$ set value 10 °C (30 °C)
10 V $\hat{=}$ set value 100 °C (120 °C)
- Boiler enabled; held at minimum temperature.
- Butterfly valve open.
- Boiler circuit pump or shunt pump enabled.

Note

On the lead boiler, the voltage must be **higher than 1 V**.

Note

Ensure DC separation between the negative pole and the earth conductor of the on-site voltage source.

Enable boiler with an additional enable contact

0 - 1 V $\hat{=}$ "No default set boiler water temperature"

Default temperature for the boiler:

Range of 0 to 100 °C (can be changed to 30 to 120 °C)

1 V $\hat{=}$ set value 10 °C (30 °C)

10 V $\hat{=}$ set value 100 °C (120 °C)

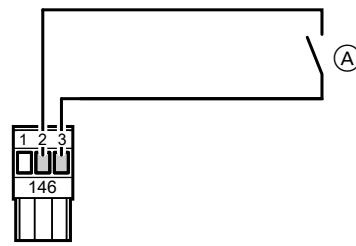

- (A) Boiler enable (floating contact)

Note

This contact must **always** be closed on the lead boiler.

Con- tact	Closed	Open
(A)	Boiler enabled; held at minimum temperature. The butterfly valve opens.	The butterfly valve is closed after approx. 5 min. External burner start not possible.

Digital data inputs DE1 to DE3

Functions:

- External blocking
- External blocking with fault message input
- Fault message input

The hooked-up contacts must correspond to safety category II.

Input function assignment

Select the input functions via the codes on the boiler control unit:

- DE1: Coding address "5d"
- DE2: Coding address "5E"
- DE3: Coding address "5F"

Output 157

Connections:

- Fault message facility

Function assignment

Select the function of output 157 via coding address "5C".

Boiler sequence control with on-site cascade control unit — connections to the Vitotronic 100, type GC1B

Switching via contacts

Operation with a two-stage burner

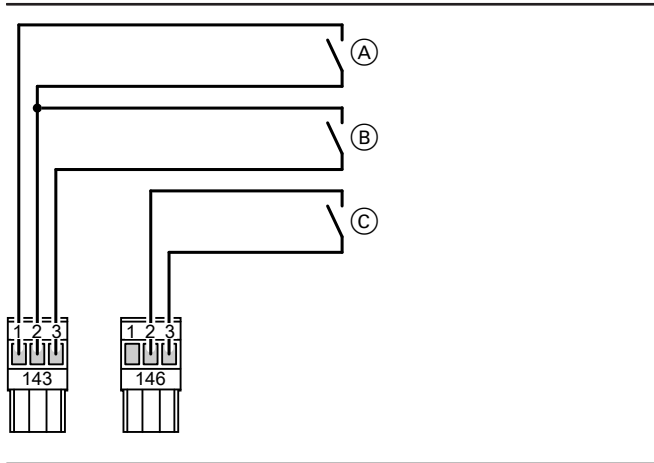

- (A) Burner stage 1 "on"
- (B) Burner stage 2 "on"
- (C) Boiler enable
Butterfly valve "Open" or "Closed"

(A), (B) and (C) are floating contacts of the higher ranking control unit.

The connections on plugs 143 and 146 are required when connecting an external control unit. The cylinder temperature and the load-dependent cascade control must be controlled by an external control unit.

Note

An "enable boiler" contact is essential for multi-boiler systems. This contact **must** always be closed on the lead boiler.

External burner start – burner stage 1

Contact at terminals "1" and "2" of plug 143

- Contact closed:
 - Burner stage 1 is switched ON.
 - Burner stage 2 is switched ON only for maintaining the minimum temperature.
 - The boiler water temperature is limited by the electronic maximum temperature limiter (see the Vitotronic 100 service instructions), if it is set below that of mechanical thermostat "0".
- Contact open:
 - Burner stage 1 is switched OFF.

External burner start – burner stage 1 and 2

Contact at terminals "2" and "3" of plug 143

- Contact closed:
 - Both burner stages are switched ON.
 - The boiler water temperature is limited by the electronic maximum temperature limiter, if it is set below that of mechanical control thermostat "0".
 - Burner stage 2 is switched OFF 2 K sooner.
- Contact open:
 - Burner stages 1 and 2 are switched OFF.

Enable boiler, butterfly valve

Contact at terminals "2" and "3" of plug 146

- Contact closed:
 - Initially, the preheat function for lag boilers is activated.
 - After the preheat function has expired, the minimum boiler water temperature will be maintained and the burner stages can be controlled externally.
- Contact open:
 - The butterfly valve is closed after approx. 5 min.
 - Burner stages cannot be switched ON externally; a minimum temperature will not be maintained.

Settings at the Vitotronic 100

Code "01:3".

The high limit safety cut-out settings and other settings depend on the system equipment level along with safety equipment to EN 12828 or EN 12953.

High limit safety cut-out	110 °C	100 °C
Temperature controller	100 °C	87 °C
Coding address "06" for electronic maximum temperature limiter (Vitotronic 100)	95 °C	85 °C
Maximum temperature of the on-site control unit	90 °C	80 °C

Note

A safety temperature of 120 °C (EN 12953) is only permissible with an additional, self-monitoring high limit safety cut-out. For an accessory pack for safety temperature 120 °C, see Viessmann pricelist.

Operation with a modulating burner

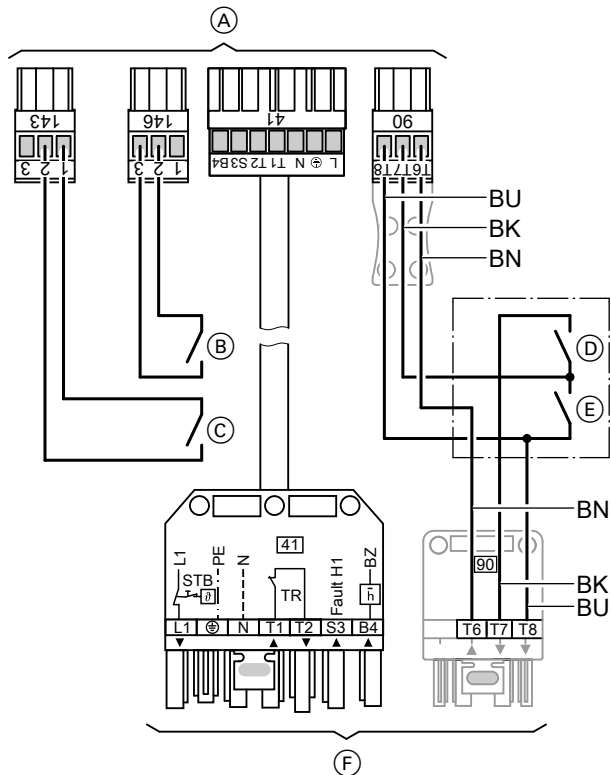

- (A) Plug to the control unit
- (B) Boiler enable
Butterfly valve "Open" or "Closed"

Control units (cont.)

- Ⓒ Burner stage 1 (base load) "on"
- Ⓓ Reduce burner output (modulation controller)
- Ⓔ Increase burner output (modulation controller)
- Ⓕ Plug to the burner

Colour coding to DIN IEC 60757

BK Black
BN Brown
BU Blue

The connections on plugs [143] and [146] are required when connecting an external control unit. The cylinder temperature and the load-dependent cascade control must be controlled by an external control unit.

Note

An "enable boiler" contact is essential for multi-boiler systems. This contact **must** always be closed on the lead boiler.

External burner start – burner stage 1

Contact at terminals "1" and "2" of plug [143]

- Contact closed:
Burner stage 1 is switched on.
The modulation (full load) is switched on only for maintaining the minimum temperature.
The boiler water temperature is limited by an electronic maximum temperature limiter (see Vitotronic 100 service instructions), subject to it being set below the mechanical temperature controller "Ⓒ".
- Contact open:
Burner stage 1 is switched off.

Modulating burner connection:

- Burner stage 1 [41] of the Vitotronic 100
- Plug [90] from the Vitotronic 100 via modulation controller (on-site) to plug [90] on the burner.
- Set the minimum temperature at the higher control unit with the modulation controller 5 K higher than the lower boiler water temperature; see operating conditions.

Hook-up of on-site control units via LON

The Vitotronic control units are equipped with an open standard LON interface. With standard LONWORKS network variables (SNVT). This universal, decentralised network for automated building control systems not only allows communication between Vitotronic control units, but also the hook-up of on-site systems and devices from various manufacturers.

Enable boiler, butterfly valve

Contact at terminals "2" and "3" of plug [146]

- Contact closed:
Initially, the preheat function for lag boilers is activated. After the preheat function has expired, the minimum boiler water temperature will be maintained and the burner stages can be controlled externally.
- Contact open:
The butterfly valve is closed after approx. 5 min. Burner stages cannot be switched ON externally; a minimum temperature will not be maintained.

Settings at the Vitotronic 100

Code "01:3".

The high limit safety cut-out settings and other settings depend on the system equipment level along with safety equipment to EN 12828 or EN 12953.

High limit safety cut-out	110 °C	100 °C
Temperature controller	100 °C	87 °C
Coding address "06" for electronic maximum temperature limiter (Vitotronic 100)	95 °C	85 °C
Maximum temperature of the on-site control unit	90 °C	80 °C

Note

A safety temperature of 120 °C (EN 12953) is only permissible with an additional, self-monitoring high limit safety cut-out. For an accessory pack for safety temperature 120 °C, see Viessmann pricelist.

Appendix

12.1 Safety regulations and requirements

Duty of notification and required permits

German Immissions Act (BImSchG)

According to paragraph 4 onwards of the German Immissions Act, in conjunction with the 4th BImSchV, a permit is required for combustion equipment with the following combustion output and for the use of the following fuels:

- Solid or liquid fuels (except fuel oil EL) with a combustion output from 1 MW
- Fuel oil EL and gaseous fuels with a combustion output from 20 MW

Permit requirement and testing to the Health & Safety at Work Act (BetrSichV) [Germany]

Extract from the Health and Safety at Work Act (BetrSichV) [Germany] paragraphs 13 to 15

Paragraph 13 Permit requirement

- (1) The assembly, installation and operation of assemblies with fired or otherwise heated pressure equipment that is at risk of being overheated, used for the generation of steam or hot water with a temperature in excess of 110 °C, which must be classified according to appendix II, diagram 5 of the Directive 97/23/EC as category IV (see Declaration of Conformity in the product documentation of Viessmann boilers), require a permit by the appropriate authority (generally the Planning Authority in your locality).
- (2) Apply for permits in writing. The permit is deemed to have been granted if the appropriate local authority does not prohibit the assembly and installation of the system within 3 months.

Paragraph 14 Testing prior to commissioning

- (1) The user must ensure that a system requiring supervision (all pressure equipment to 97/23/EC) is tested by an approved inspection body for compliant status.
- (3) Tests in accordance with (1) can be carried out by an authorised person on pressure equipment and assemblies that are to be classified in accordance with Directive 97/23/EC and diagram 5 as category I or II.

Paragraph 15 Recurring tests

- (8) For pressure equipment and assemblies that are classified in accordance with Directive 97/23/EC and diagram 5 as category III, implement the following recurring tests, subject to the product of maximum permissible pressure PS and the crucial volume V being greater than 1000 bar · l, or if they are classified as category IV.
For Viessmann boilers, the following test periods are suggested:
 - external inspection no later than 12 months after commissioning
 - internal inspection no later than 3 years after commissioning (alternatively water pressure test with the maximum test pressure according to type plate)
 - strength test no later than 9 years after commissioning.

General information regarding low pressure hot water boilers with safety temperatures of up to 110 °C/120 °C

Viessmann boilers are manufactured and must be equipped in compliance with currently applicable standards and directives. For further details, see the Declaration of Conformity and the chapters concerning equipment and operation. Observe the operating conditions stated in these guidelines.

During installation and commissioning of a boiler, observe all local Building Regulations and regulations concerning combustion systems, as well as the following standards, regulations and directives:

- **DIN 18160-1**: Flue systems (design versions).
- **DIN 1988**: Technical Regulations for Drinking Water Installations (TRWI).
- **DIN 4753**: DHW systems for DHW and process water.
- **EN 12828**: Heating systems in buildings – Design of hot water heating systems.
- **EN 13384**: Flue systems – Thermal and flow calculations.
- **TRD 702**: Equipment level for steam boiler systems with class II hot water boilers.
- **Also observe EN 12953** with:
 - Low pressure hot water boilers with safety temperatures > 110 to 120 °C.
- **EN 12953-1**: Shell boilers – General information.
- **EN 12953-6**: Shell boilers – Equipment requirements.
- **EN 12953-7**: Shell boilers – Requirements for combustion systems for liquid or gaseous fuels for the boiler.
- **EN 12953-8**: Shell boilers – Safety valve requirements.

- **EN 12953-10**: Shell boilers – Feedwater and boiler water requirements.
- **EN 14394**: Boilers – boilers with pressure-jet burners – rated heating output lower or up to 10 MW and a maximum operating temperature of 110 °C.

Use of oil combustion

- **DIN 4755**: Oil combustion equipment.
- **DIN 4787-1**: Atomising oil burner (in excess of 100 kg/h throughput).
- **DIN 51603-1**: Liquid fuels; fuel oil EL, minimum requirements.
- **EN 230**: Atomising oil burners as mono block version – equipment for safety, monitoring and control, as well as safety times.
- **EN 267**: Pressure-jet oil burners.
- **TRD 411**: Oil combustion for steam boilers (where applicable).

Use of gas combustion

- **EN 298**: Burner control units for gas burners and pressure-jet or atmospheric gas devices.
- **EN 676**: Pressure-jet gas burners.
- **DVGW Code of Practice G 260/I and II**: Technical rules for gas quality.
- **DVGW-TRGI 2008**: Technical rules for gas installations.
- **TRD 412**: Gas combustion for steam boilers (where applicable).
- **TRF 1996**: Technical rules for LPG.

Sizing the flame tube

The permissible combustion output is regulated by DIN EN 12953 and the relevant trade association agreement. For this, take the material thickness, internal diameter and fuel into account when sizing the flame tube.

Regulations	DIN EN 12953 or TRD with trade association agreement 2003/1
Max. combustion output	
Oil combustion	14.0 MW
Gas combustion	18.2 MW
Material	P265GH (max. 8 MW oil combustion, max. 10.4 MW gas combustion) P355GH
Max. nominal wall thickness	22 mm

Flame tube temperature monitor

EN 12953 part 3/point 5.4 refers to national regulations which may state that a temperature measuring system (= flame tube temperature monitor) is required, subject to the internal diameter of the flame tube and the combustion output.

For Germany, the use of flame tube temperature monitors is regulated by the trade association agreement 2003/1 as follows.

Flame tube temperature monitor required:

- for flame tube internal diameter > 1800 mm and/or
- for combustion heating output > 14,000 kW (oil combustion) > 18,200 kW (gas combustion)

Gas installation

The gas installation should be carried out by a registered installer in accordance with the technical connection requirements stipulated by the gas supply utility. Operate the system in accordance with the above conditions.

Pipe connections

All pipe connections to the boiler should be made free from stress and torque. Applying loads and torques into the boiler is not permissible.

Electrical installation

Carry out the electrical connection and installation in accordance with VDE regulations (DIN VDE 0100 and DIN VDE 0116), local regulations and the technical connection requirements laid down by your power supply utility.

- **DIN VDE 0100:** Installation of HV systems with rated voltages up to 1000 V.
- **DIN VDE 0116:** Electrical equipment for combustion systems.

Operating instructions

According to EN 12828, section 5 and EN 12170/12171, the system installer must provide operating instructions for the whole system.

Flue system

Only flue pipes approved by the building inspectorate may be used with condensing systems.

German Immissions Order (BImSchV)

Combustion systems must be operated so that the limits stated in the 1st BImSchV of 26.01.2010 or the TA Luft – for systems listed in the 4th BImSchV of 11.08.2009 – will not be exceeded. The 1st BImSchV applies to oil and gas combustion systems for heating buildings or rooms with water as a heat transfer medium.

■ 1st BImSchV, paragraph 6

Section 3, oil and gas combustion systems

- Oil and gas combustion systems > 400 kW for heating buildings or rooms:

The manufacturer must certify that the efficiency is $\geq 94\%$ (calculated to EN 303–5, version 6/1999).

- The requirements of section 3 are deemed to have been met for boilers > 1 MW if the boiler efficiency is $\eta_K \geq 94\%$ (calculated to DIN 4702-2).

- The nitrogen oxide content in flue gas for oil and gas combustion systems > 0.4 MW < 10 MW used for heating buildings and rooms must not exceed 185 mg/kWh when using fuel oil EL or, for natural gas, 120 mg/kWh.

■ 1st BImSchV, paragraph 11a

Oil and gas combustion systems from 10 MW to 20 MW: Single combustion systems with a combustion output between 10 and < 20 MW may only be operated, if the emission values in the following table (as average values over half an hour) are not exceeded:

	Fuel oil EL	Natural gas	Alternative gases	Operating temperature
CO	$\leq 80 \text{ mg/m}^3$ flue gas	$\leq 80 \text{ mg/m}^3$ flue gas		
NO _x	$\leq 180 \text{ mg/m}^3$ flue gas $\leq 200 \text{ mg/m}^3$ flue gas	$\leq 100 \text{ mg/m}^3$ flue gas $\leq 110 \text{ mg/m}^3$ flue gas	$\leq 200 \text{ mg/m}^3$ flue gas	< 110 °C 110 °C to ≤ 210 °C irrespective of the operating temperature

Checks as part of the Building Regulations approval process

As part of the Building Regulations approval process, condensing combustion equipment is tested by the flue gas inspector (where applicable) for adherence to Building Regulations and any generally recognised technical rules.

The State Building Regulations, their implementation orders and the combustion equipment orders, as well as the general building approvals and permits of the higher supervisory authority, in individual cases, are part of the Building Regulations requirements.

Keyword index

A		H	
Additional functions.....	64	Halogenated hydrocarbons.....	25
Airborne noise attenuation.....	31	Handling.....	25
B		Health & Safety at Work Act (BetrSichV) [Germany].....	69
Blocking, external.....	63, 64	Heating circuit pump.....	28
Boiler blocking.....	64	Heating connections.....	27
Boiler circuit pump.....	27	Heating program changeover.....	62, 64
Boiler control platform.....	26	High limit safety cut-out.....	29
Boiler control units.....	36	I	
Boiler cover.....	26	Immersion thermostat.....	54
Boiler efficiency.....	6, 7, 9, 10, 12, 13, 14	Installation room.....	25
Boiler sequence.....	64	Insulation against structure-borne noise.....	32
Boiler thermometer.....	29	L	
Boiler water temperature sensor.....	38	Low salt content in water.....	32
Building Regulations approval process.....	71	Low water indicator.....	29
Burners.....	30	M	
Butterfly valve.....	68, 69	Maximal pressure limiter.....	29
C		Maximum pressure limiter.....	29
Chemicals for corrosion protection.....	34	Minimum pressure limiter.....	29
Combustible materials.....	26	Mixer open.....	62, 64
Combustion air.....	26	Modulating burner.....	66, 68
Combustion Order.....	30	Modulating burner connection.....	66, 69
Connection 0 – 10 V.....	62, 64, 66	Multi boiler system.....	68
Constant temperature control		Multi boiler systems.....	37
■ Programming unit.....	39	Multi stage/modulating burner.....	63
Contact temperature sensor.....	51	O	
Contact thermostat.....	54	On-site control unit.....	62, 64, 65, 66, 68
Control panels.....	36	Operating conditions.....	6, 8, 9, 11, 12, 13, 14
Control thermostat.....	29	Outside temperature sensor.....	39
Control units.....	36	P	
Corrosion.....	34	Permit requirement in accordance with the BetrSichV [Germany]...70	
Corrosion protection measures.....	34	plug ¹⁴³	64
Cylinder temperature sensor.....	39, 53	Plug ¹⁴³	62, 64
D		Plug ¹⁴⁶	63
Delivery.....	25	Pressure Equipment Directive.....	9, 12, 14
Design.....	26	Pump controlled pressure maintaining systems.....	27
Diaphragm expansion vessel.....	34	R	
E		Requirements for installation room.....	25
Efficiency, how to increase.....	34	Requirements of the Sample Combustion Order [Germany].....	30
Emergency stop switch.....	26	Room temperature sensor.....	51
Enable boiler.....	68, 69	S	
EnEV.....	42, 44	Safety equipment.....	28
Expansion vessel.....	27, 34	Safety precautions.....	26
Extension AM1.....	57	Safety temperature.....	26, 29
Extension EA1.....	57	Saline water.....	33
External blocking.....	63, 64	Shunt pump.....	27
External burner start.....	65, 66, 68, 69	Single boiler system.....	65
External changeover of multi stage/modulating burners.....	63	Single boiler systems.....	36
External demand.....	63, 64	Siting.....	25
External heating program changeover.....	62, 64	Sizing.....	31
External load-dependent starting.....	63, 64	Solar control module	
External starting subject to load.....	65	■ Specification.....	56
F		Sound insulation.....	31
Flash trap.....	29	Sound insulation accessories.....	32
Flow temperature.....	6, 7, 9, 10, 12, 13, 14, 26, 32	Specification	
Flue gas temperature sensor.....	52	■ Solar control module.....	56
Fuels.....	29	■ Vitotrans 300.....	20
G		Standard seasonal efficiency.....	14
Gas Appliances Directive.....	9, 12, 14	Starting, load-dependent.....	63, 64
German Immissions Act (BImSchG).....	69, 71	Starting subject to load.....	65
		Switching points.....	38

Keyword index

T

Temperature sensor	
■ Contact temperature sensor.....	51
■ Room temperature sensor.....	51
■ Wireless outside temperature sensor.....	50
Temperature sensors	
■ Boiler water temperature sensor.....	38
■ Cylinder temperature sensor.....	39, 53
■ Flue gas temperature sensor.....	52
■ Outside temperature sensor.....	39
Tests according to the BetrSichV [Germany].....	69
Thermostat	
■ Contact temperature.....	54
■ Immersion temperature.....	54
Two-stage burner.....	65, 68

V

Vitocom	
■ 100, type GSM.....	58
■ 100, type LAN1.....	58
■ 200, type GP1.....	59
■ 300, type FA5, FI2, GP2.....	59
Vitotrol	
■ 200A.....	46
■ 200 RF.....	48
■ 300A.....	47
■ 300 RF with table-top dock.....	48
■ 300 RF with wall mounting bracket.....	49

W

Water quality, standard values.....	32
Water-side corrosion.....	34
Water treatment.....	34
Wireless components	
■ Wireless base station.....	50
■ Wireless outside temperature sensor.....	50
■ Wireless remote control.....	48, 49
■ Wireless repeater.....	51





Subject to technical modifications.

Viessmann Werke GmbH&Co KG
D-35107 Allendorf
Telephone: +49 6452 70-0
Fax: +49 6452 70-2780
www.viessmann.com

Viessmann Limited
Hortonwood 30, Telford
Shropshire, TF1 7YP, GB
Telephone: +44 1952 675000
Fax: +44 1952 675040
E-mail: info-uk@viessmann.com

5822 427 GB